



ISO 9001 ISO 14001 CE
A Worldwide Tradition of Quality Products and Customer Service

Multi-tasking Turning Center TB-20Y/25Y Series

High ■Quality ■Precision ■Efficiency ■Economy



Global Sales & Service Network

★ Head Office ● Branch ● Foreign Agency ● Factory

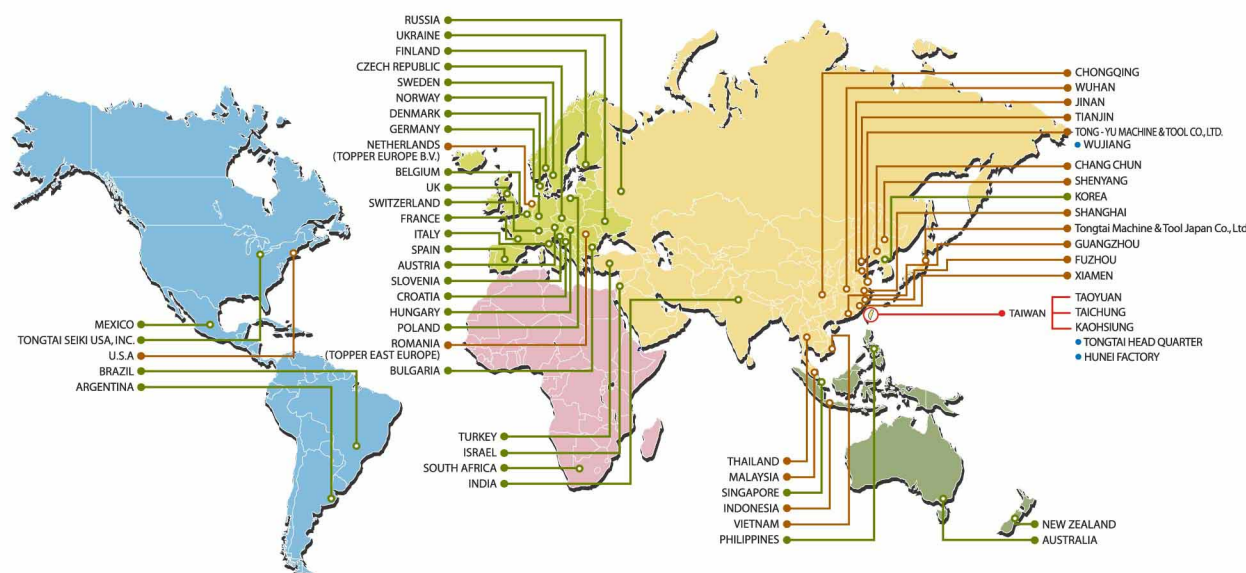

Tongtai Machine & Tool Co., Ltd.

• HEAD OFFICE
NO.3, LUKE 3rd. RD., LUZHU DISTRICT, KAOHSIUNG CITY, 82151, TAIWAN.
TEL : 886-7-9761588 FAX : 886-7-9761589/886-7-9761590
Website : <http://www.tongtai.com.tw>

• TAOYUAN OFFICE TEL : 886-3-4551399 FAX : 886-3-4559730
• TAICHUNG OFFICE TEL : 886-4-23589313 FAX : 886-4-23588913
• TONGTAI SEIKI U.S.A INC. TEL : 1-845-2675500 FAX : 1-845-2675546
• Tongtai Machine & Tool Japan Co., Ltd TEL : 81-4-71438355 FAX : 81-4-71438360
• TONGTAI SEIKI VIETNAM LIMITED TEL : 84-435112529
• EUROPE OFFICE TEL : 31-161-454639 FAX : 31-161-454768
• THAILAND OFFICE TEL : 66-2-7443440 FAX : 66-2-3986518
• INDONESIA OFFICE TEL : 62-21-45850521 FAX : 62-21-45840522
• MALAYSIA OFFICE TEL : 60-3-78456815 FAX : 60-3-78456851

• CHINA OFFICE
SHUZHOU TONG-YU MACHINE & TOOL CO., LTD.
TEL : 86-512-63430168 FAX : 86-512-63431622
E-mail : sales@tong-yu.com.cn

• WUHAN OFFICE TEL : 86-27-59409109 FAX : 86-27-59409110
• SHANGHAI OFFICE TEL : 86-21-24208138 FAX : 86-21-34073262
• CHONGQING OFFICE TEL : 86-23-67865925 FAX : 86-23-67867717
• GUANGZHOU OFFICE TEL : 86-755-27222119 FAX : 86-755-27222115
• TIANJIN OFFICE TEL : 86-22-24417640 FAX : 86-22-24416738



***The Economic Solution for
Multi-Tasking Applications***

Compound of turning and milling functions plus Y axis, TB-20Y/25Y series can finish complicated machinings in one machine setup and creates the best investment income.

Symmetrical 90 degree saddle design makes X/Y/Z axis perpendicular to each other with a really linear Y axis. This design allows servo compensation on each axis to optimize the positioning accuracy.

Various options create the most suitable machining solution for high cost-performance.

TB-20Y/25Y Series

TB-20Y Series

TB-20Y Series

Ø100 mm spindle (std.)
CS axis function/belt type
Ø120 mm spindle (opt.)
CS axis function/belt type

Power turret-12 stations (VDI-40)

Tailstock-hyd. (opt. servo)

TB-20Y

Power turret-12 stations (VDI-40 long neck type)

Ø90 mm built-in sub-spindle
Servo driven (opt. CS axis)

TB-20YB

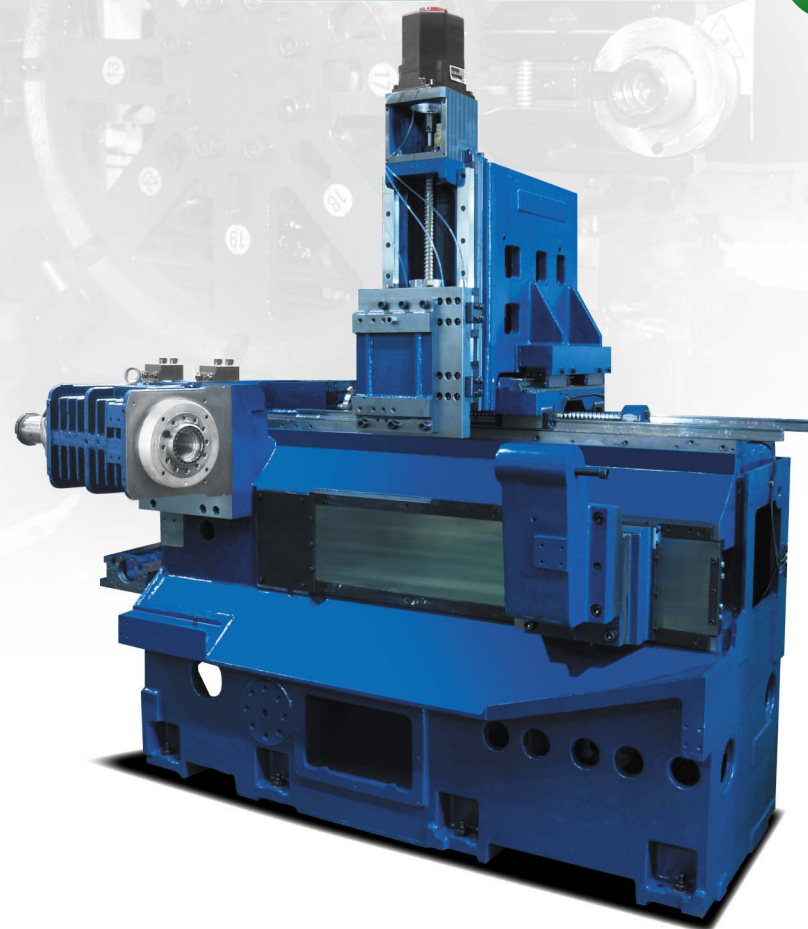

Turning capacity		
	TB-20Y	TB-20YB
Max. swing dia.	Ø620 mm	Ø620 mm
Max. turning dia.	Ø330 mm	Ø330 mm
Max. turning length	570 mm	540 mm
Spindle chuck	8"	8"
Sub-spindle chuck	-	6"
Max. drilling dia.*	20 mm	20 mm
Max. tapping*	M16	M16
Controller	FANUC 0i-T (opt. 18i-T or 31i)	

*Material : S45C

TB-25Y Series

TB-25Y Series

Ø130 mm spindle
CS axis function/
built-in type

Power turret-12 stations (VDI-40)

Tailstock-hyd. (opt. servo)

TB-25Y

Power turret-12 stations (VDI-40 long neck type)

Ø90 mm built-in sub-spindle
servo driven (CS axis)

TB-25YB

Power turret-12 stations & ATC with 8 stations

Tailstock-hyd. (opt. servo)

TB25Y-ATC

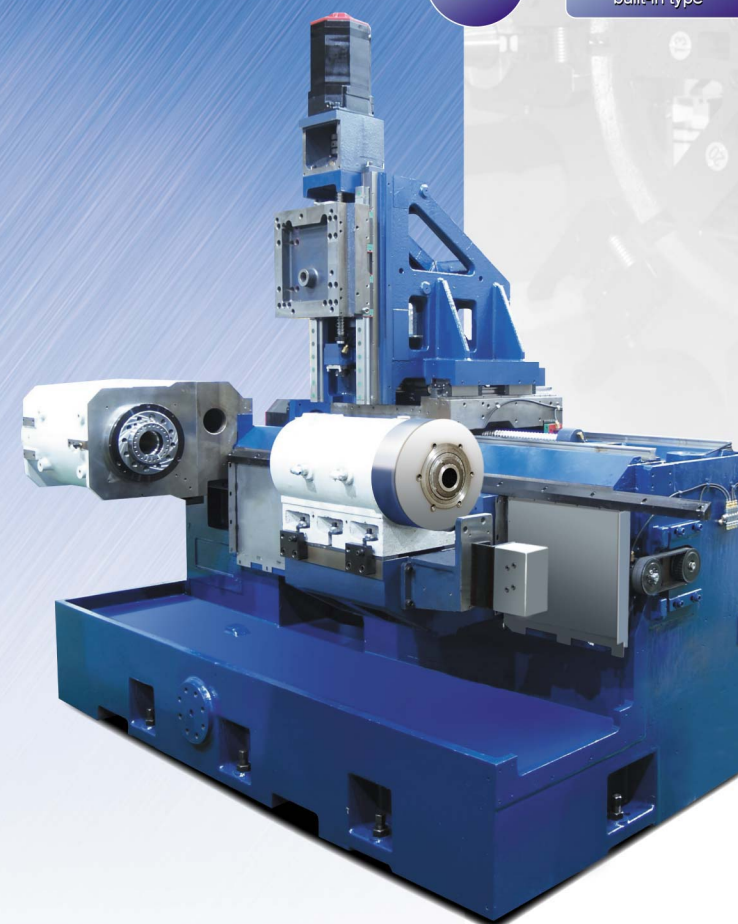

Turning capacity			
	TB-25Y	TB-25YB	TB25Y-ATC
Max. swing dia.	Ø620 mm	Ø620 mm	Ø600 mm
Max. turning dia.	Ø432 mm	Ø432 mm	Ø495 mm
Max. turning length	610 mm	610 mm	600 mm
Spindle chuck	10"	10"	10"
Sub-spindle chuck	-	8"	-
Max. drilling*	20 mm	20 mm	20 mm
Max. tapping*	M16	M16	M16
Controller	FANUC 18i-T (opt. 31i)		

* Material : S45C

Spindle module



Ø100 mm belt type spindle (CS axis)-std.



Ø120 mm belt type spindle (CS axis)-opt.

Turret module



Power turret 12 stations (VDI-40)

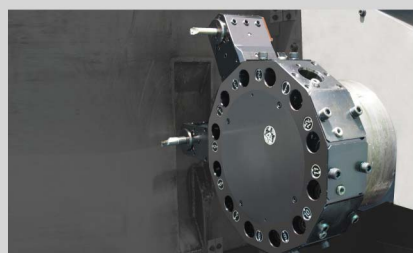

Power turret 12 stations (VDI-40 long neck type)

Tailstock / Sub-spindle module



Hyd. tailstock (opt. servo)



Ø90 mm built-in sub-spindle (opt. CS axis function)

Spindle module



Ø130 mm built-in spindle (CS axis)-std.

Tailstock / Sub-spindle module



Hyd. tailstock (opt. servo)



Ø90 mm built-in sub-spindle (opt. CS axis function)

Turret module

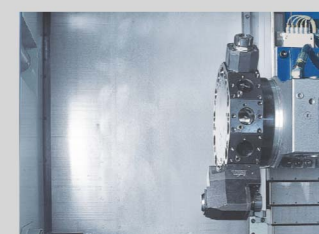

Power turret : 12 stations (VDI-40)

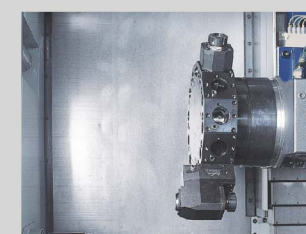

Power turret : 12 stations (VDI-40 long neck type)

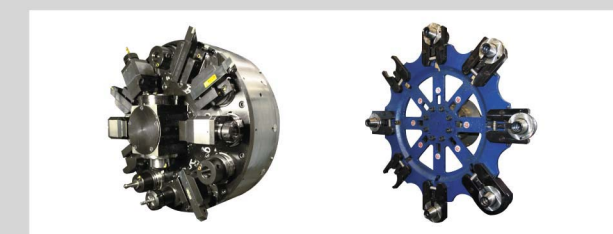

Power turret : 12 stations & ATC : 8 stations

Long-term machining stability

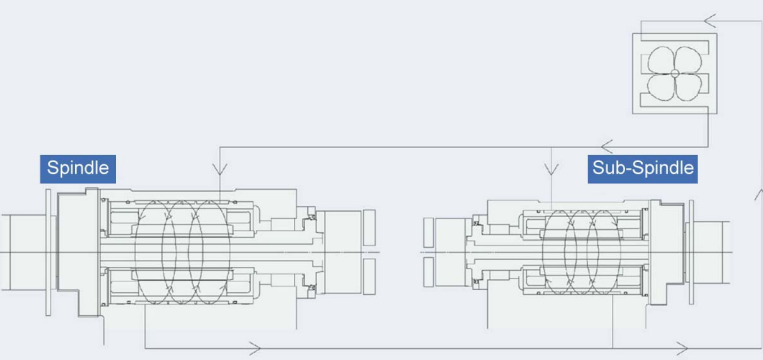

- With synchronous temperature control, the spindle cooler prevents both spindles (for built-in type only) from thermal distortion. This ensures high precision machining for long-term operation.

Multi-tasking structure

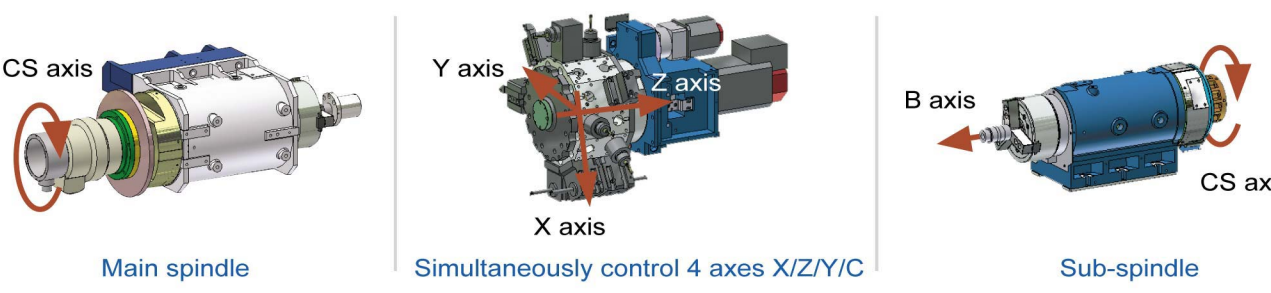

- Design concepts are to save the spending of jig, shorten the time of loading / unloading the workpiece and improve the investment returns for clients.

Main spindle CS function with rotary encoder

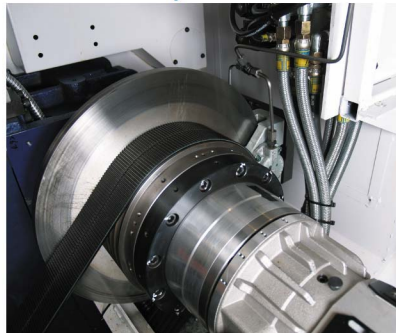

Sub-spindle CS function with rotary encoder



Spindle cooler



Workpiece exchange

Both spindles are aligned with excellent concentricity and allow workpiece exchange at synchronous speed. Thanks to the compound turning and milling functions, most of complicated parts are possible to be finished in one machine setup.

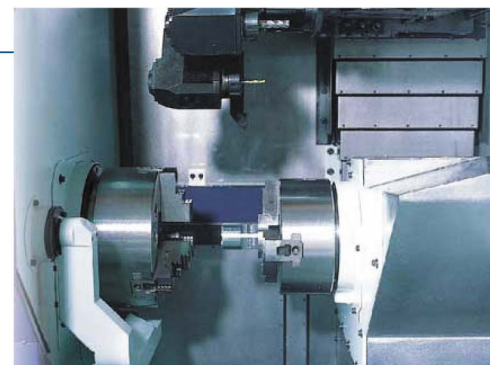

90 degree saddle



- 90 degree saddle makes X/Y/Z axis perpendicular to each other and possible for servo compensation on each linear axis to optimize the positioning accuracy.

Excellent chip flow

TB-20Y Series

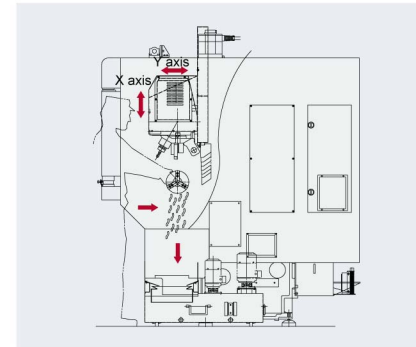

Y-axis structure

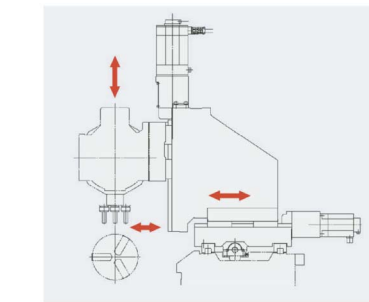

- With live tools, Y axis movement allows off-center machining.

Operational advantages

TB-20Y Series

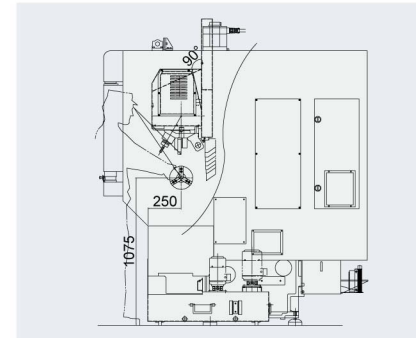

TB-25Y Series

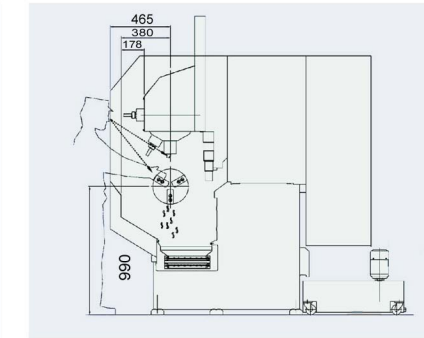

Tailstock



- Tailstock with high rigidity linear guide ways for providing high rigidity and excellent positioning accuracy.

- 90 degree saddle for easy chip flow.
- Extended chip flow exit in chip conveyor.
- 90 degree suspended sub-spindle prevents chips stocked.
- High capacity coolant tank with high pressure coolant pump to remove chips.

- The distance between spindle center and operator matches ergonomic design.
- 90 degree saddle makes tool changing easier.
- Easy monitoring the machining situation.

Control panel



- Swivel control panel facilitates the operator in monitoring the production process during program editing.

TB-20Y Series

■ Spindle motor β18iP

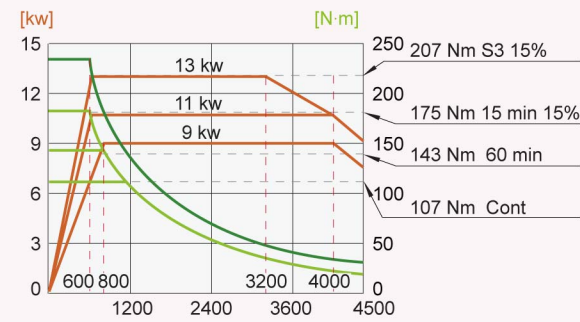

■ Sub-spindle motor αB112M (built-in)

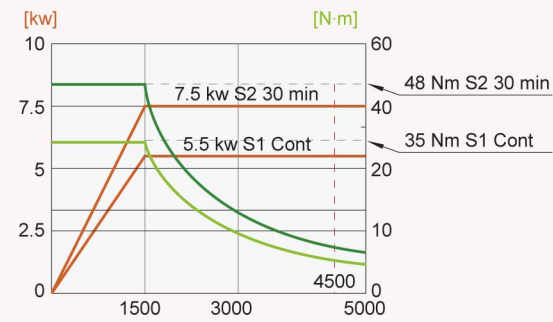

■ Power turret motor β3

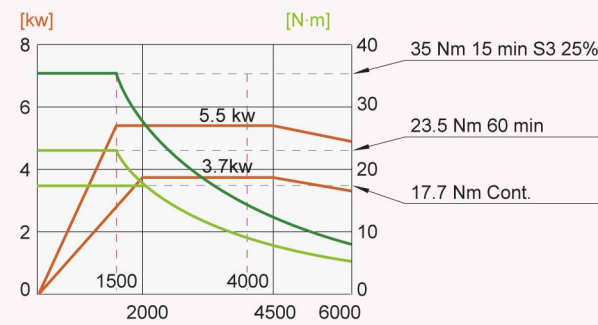

TB-20YB Turning capacity Unit:mm		
	1st spindle (S1)	2nd spindle (S2)
O.D. turning	4×0.4	4×0.3
I.D. turning	4×0.4	4×0.2
Face milling	4×0.4	4.5×0.3
O.D. grooving	6×0.1	8×0.1
I.D. grooving	5×0.1	5×0.1
Center drilling	Ø 32×0.25	Ø 25×0.3
S1 spindle motor : 11/9 kw		
S1 max. spindle speed : 4500 rpm		
S2 spindle motor : 7.5/5.5 kw		
S2 max. spindle speed : 5000 rpm		

* Material:S45C

TB-25Y Series

■ Spindle motor αB180M (built-in)

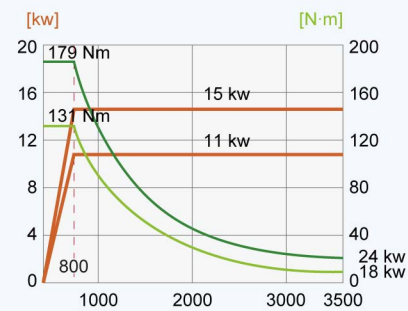

■ Sub-spindle motor αB112M (built-in)

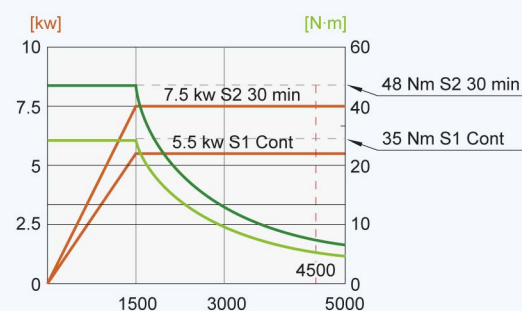

■ Power turret motor α3

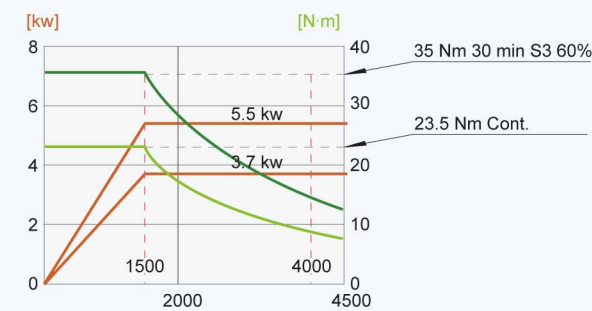

TB-25YB Turning capacity Unit:mm		
	1st spindle (S1)	2nd spindle (S2)
O.D. turning	4×0.5	4×0.3
I.D. turning	4×0.5	4×0.2
Face milling	4×0.45	4.5×0.3
O.D. grooving	8×0.1	8×0.1
I.D. grooving	6×0.1	5×0.1
Center drilling	Ø 32×0.4	Ø 25×0.3
S1 spindle motor : 15/11 kw		
S1 max. spindle speed : 3500 rpm		
S2 spindle motor : 7.5/5.5 kw		
S2 max. spindle speed : 5000 rpm		

* Material:S45C

Tooling system

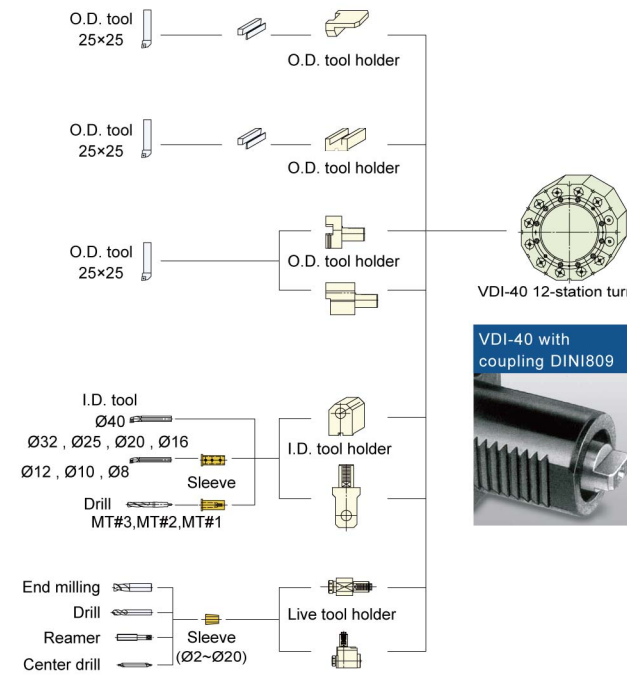

Tool interference

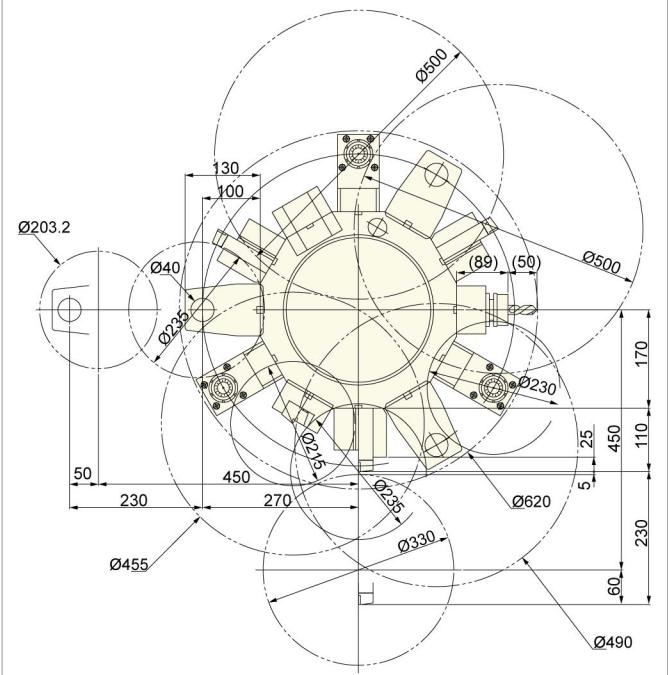

Working area TB-20Y

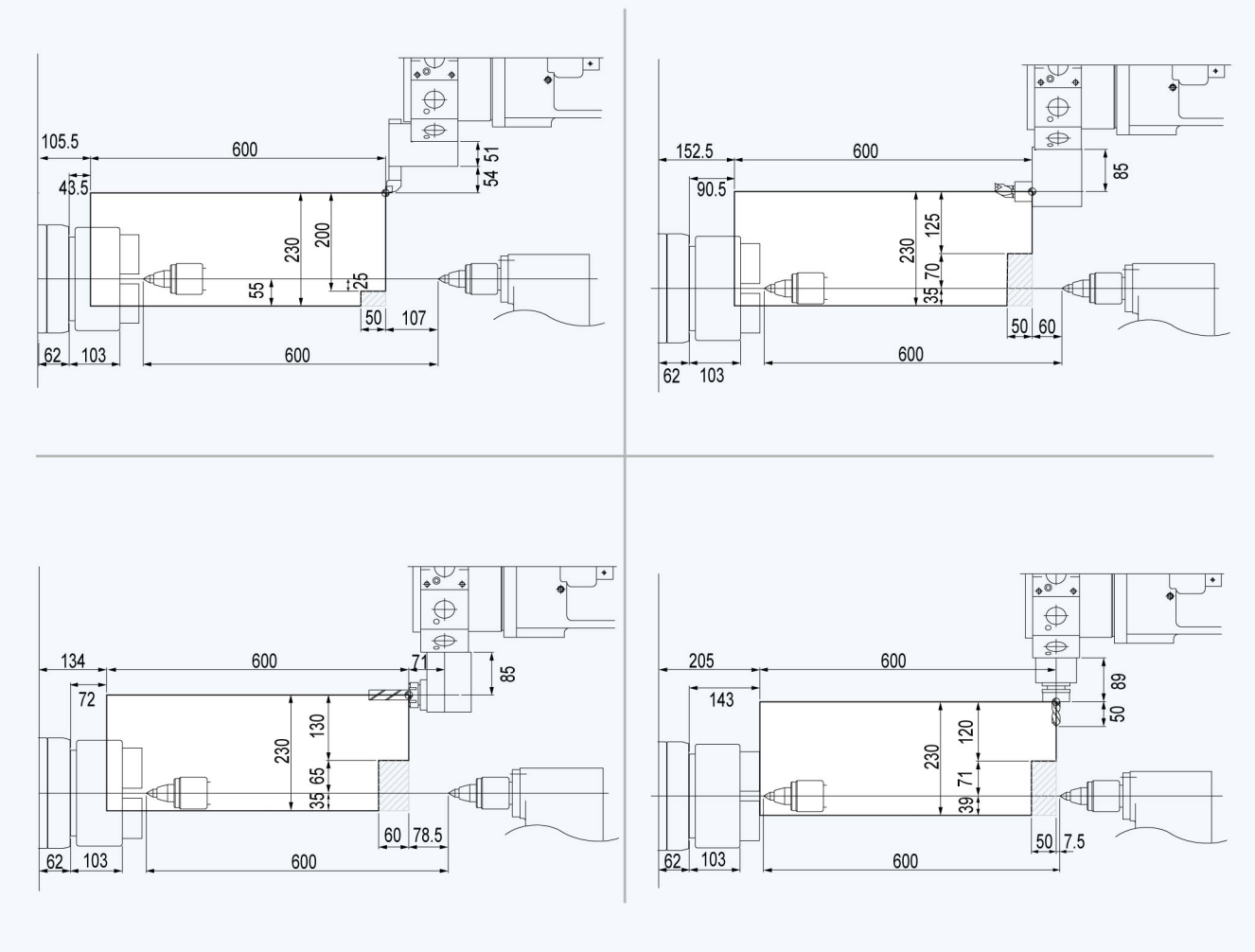

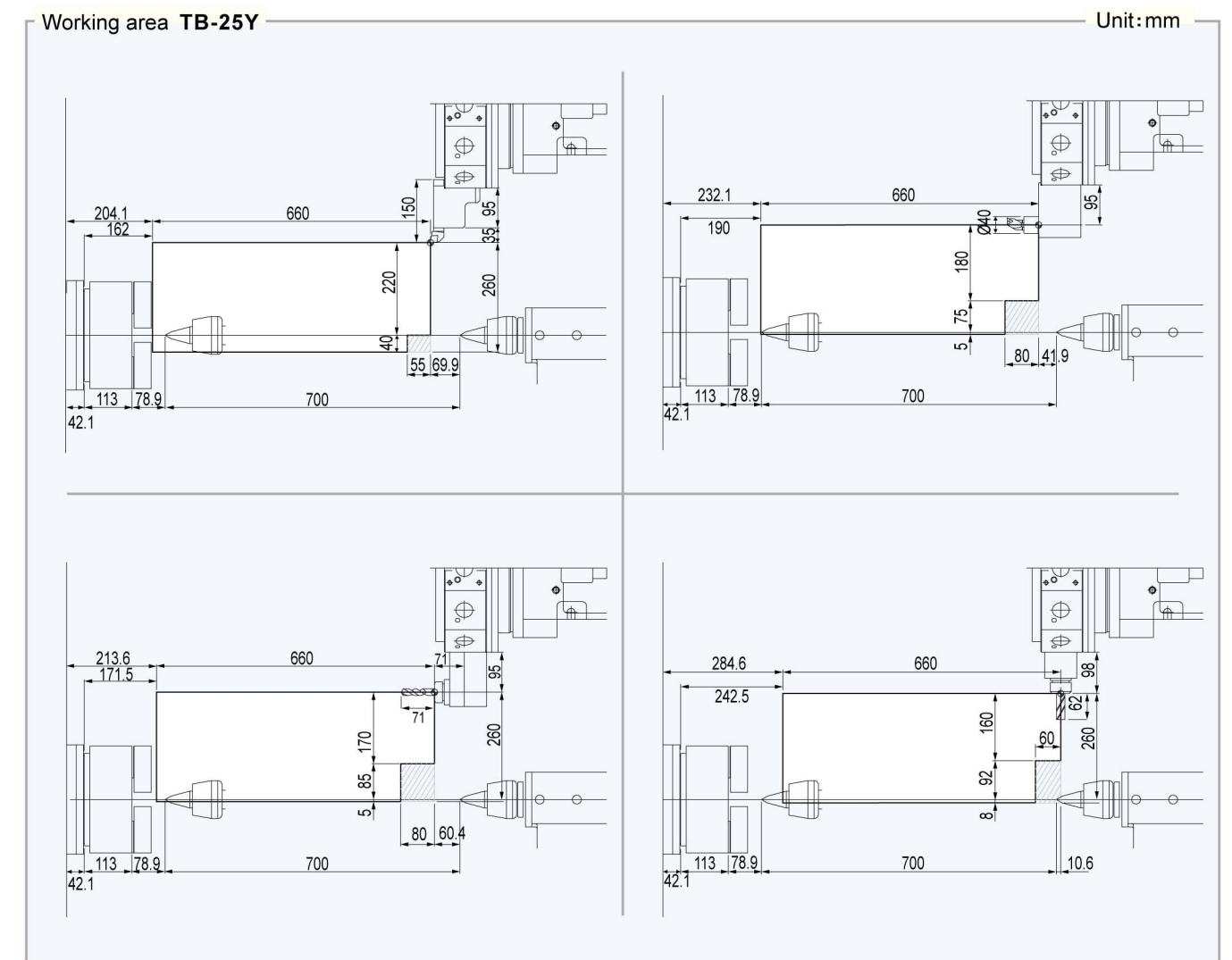
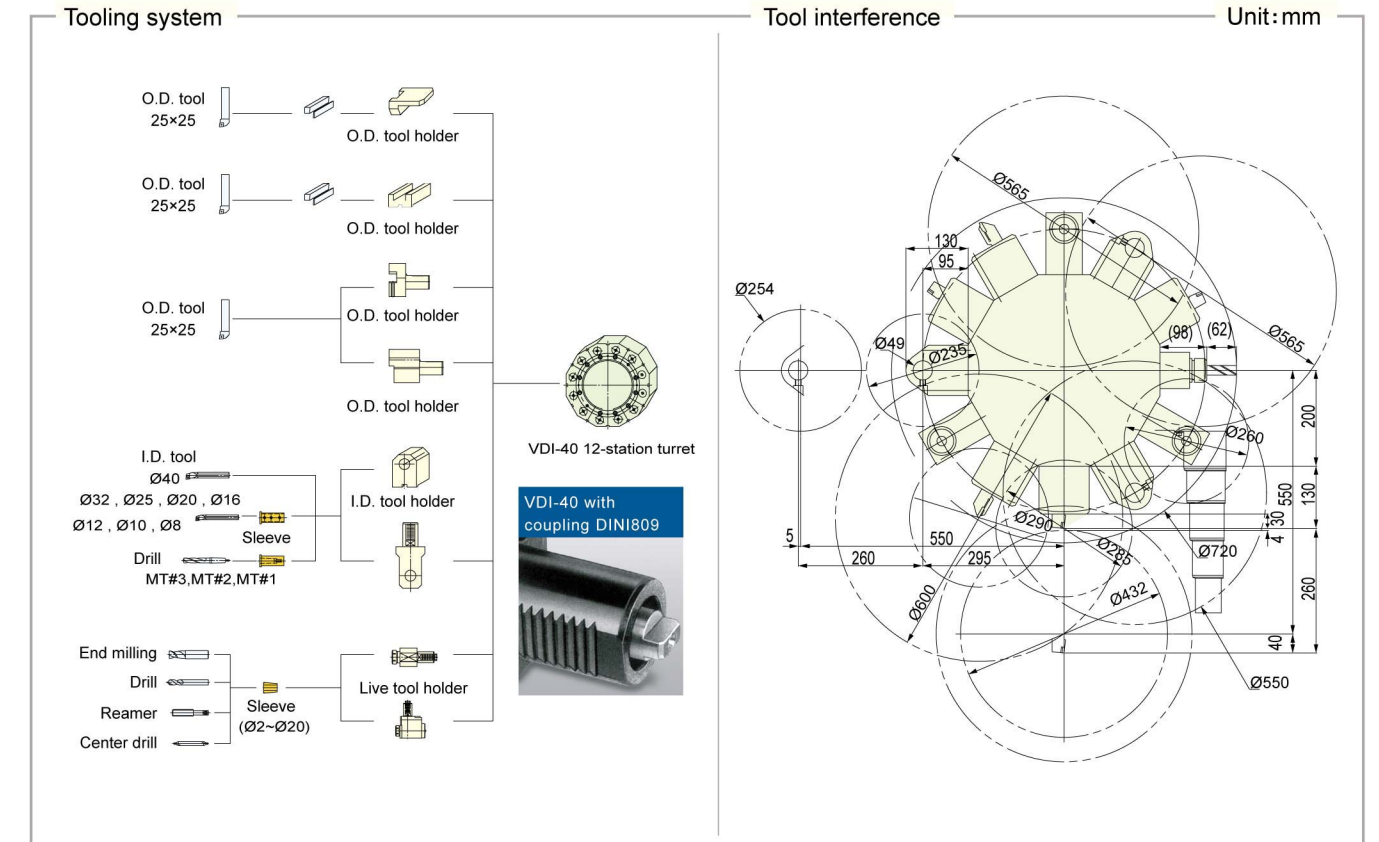
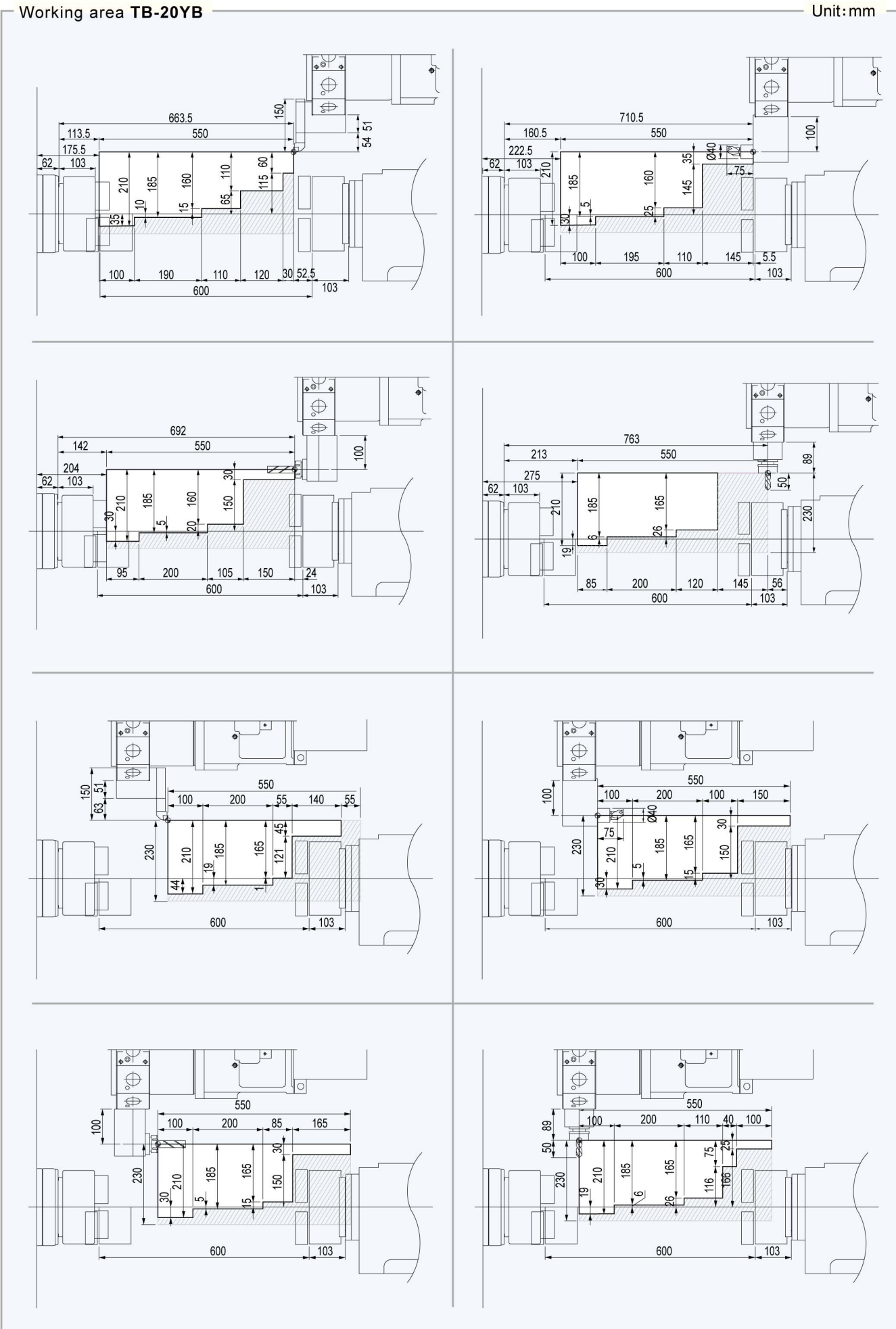

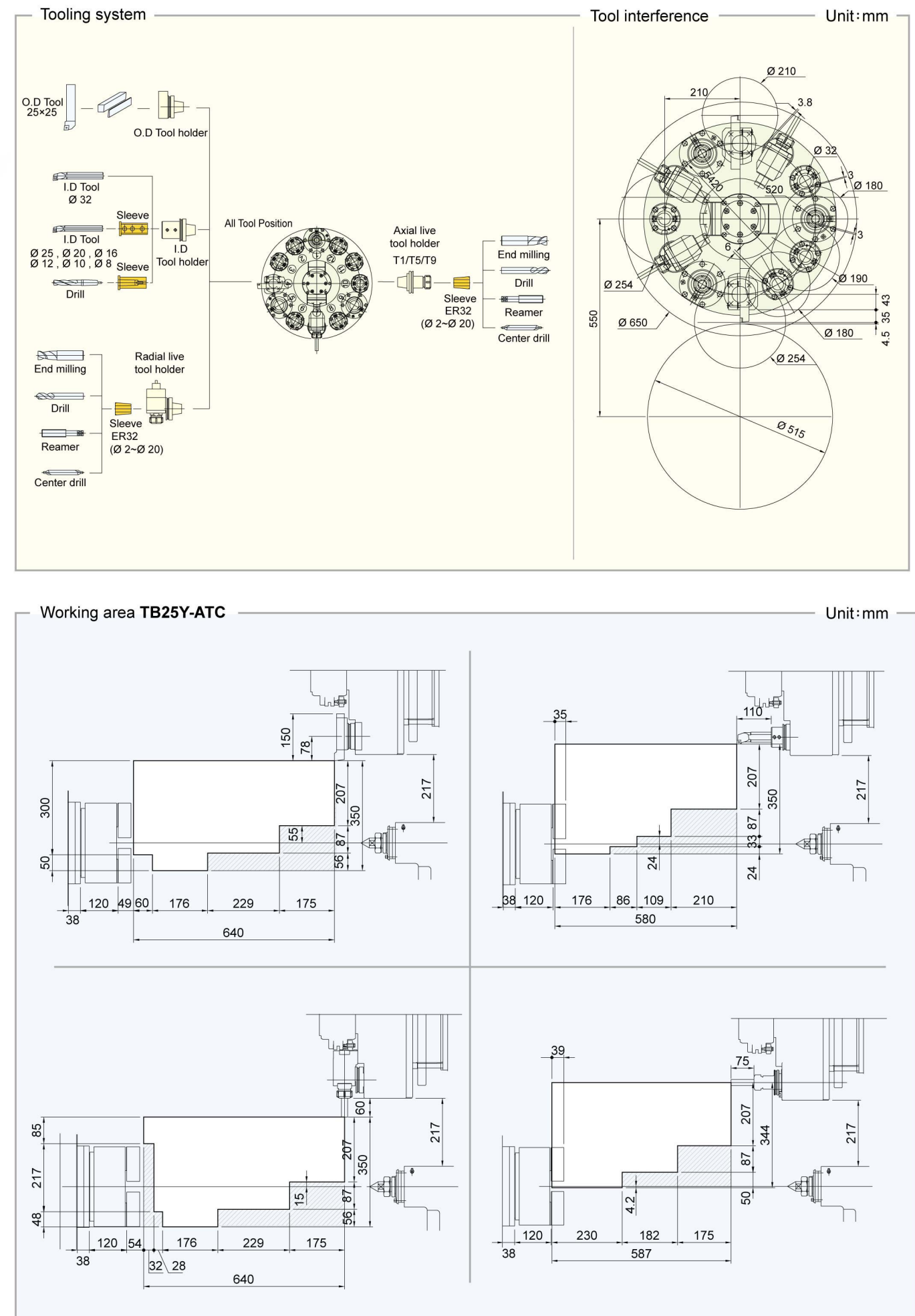
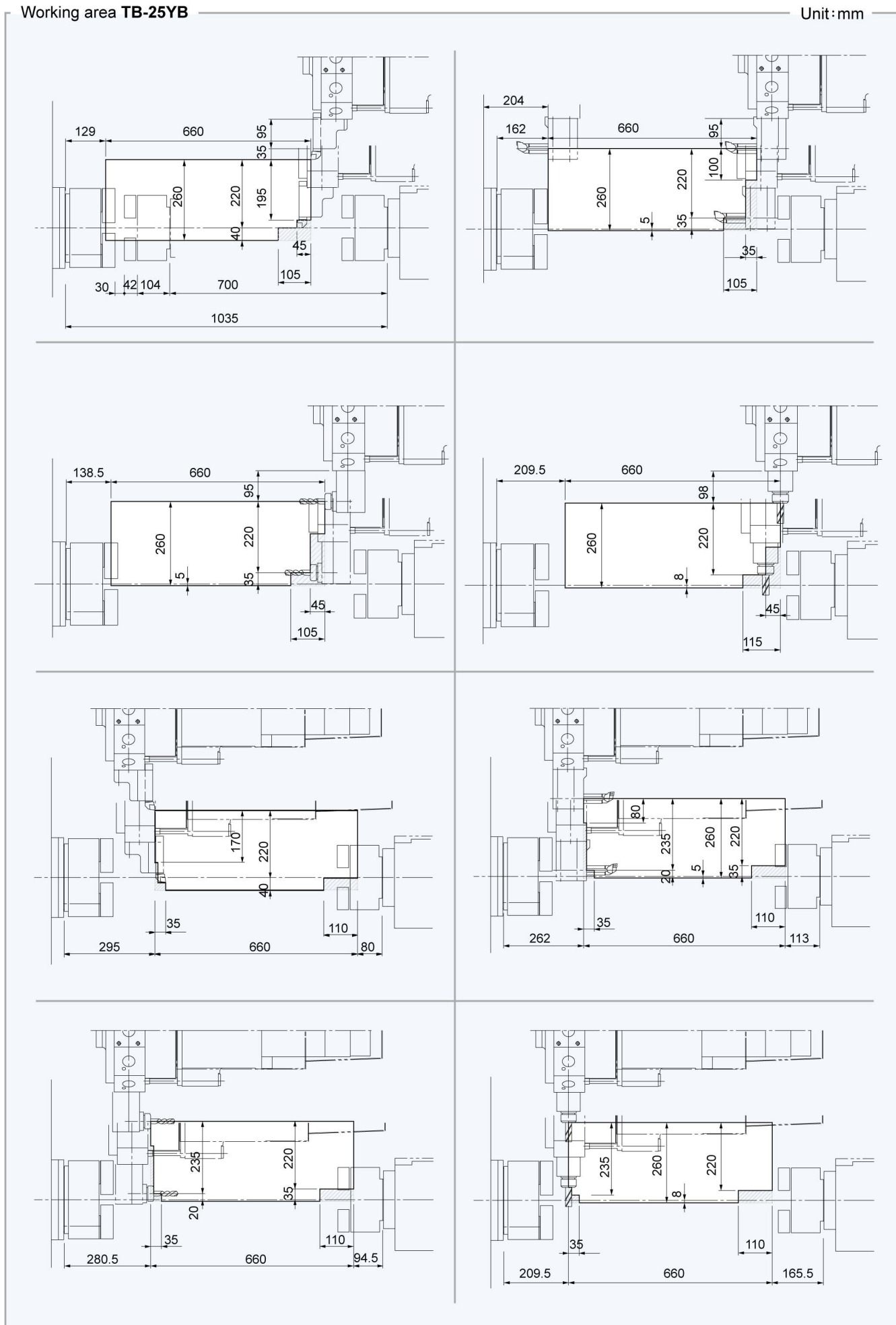

Item	Specification	Unit	TB-20Y	TB-20YB	TB-25Y	TB-25YB	TB25Y-ATC
Turning capacity	Max. swing diameter	mm	Ø620	Ø620	Ø620	Ø620	Ø600
	Max. swing diameter over saddle	mm	Ø340	Ø340	Ø480	Ø480	Ø600
	Max. turning diameter	mm	Ø330	Ø330	Ø432	Ø432	Ø495
	Max. turning length	mm	570	540	610	610	600
Spindle	Spindle nose		A2-6	A2-6	A2-8	A2-8	A2-8
	Spindle speed	rpm	4500	4500	3500	3500	3500
	Chuck size	inch	8"	8"	10"	10"	10"
	Through-spindle hole diameter	mm	Ø62	Ø62	Ø80	Ø80	Ø78
	Bar capacity	mm	Ø51	Ø51	Ø64	Ø64	Ø64
	Spindle bearing diameter	mm	Ø100	Ø100	Ø130	Ø130	Ø130
	Spindle center to floor	mm	1075	1075	990	990	990
	Min. CS axis indexing increment	deg	0.001°	0.001°	0.001°	0.001°	0.001°
	Sub-spindle	Spindle nose		-	A2-5	-	A2-5
Spindle speed		rpm	-	5000	-	5000	-
Chuck size		inch	-	6"	-	8"	-
Through-spindle hole diameter		mm	-	Ø35	-	Ø35	-
Spindle bearing diameter		mm	-	Ø90	-	Ø90	-
Min. CS axis indexing increment (opt.)		deg	-	0.001°	-	0.001°	-
ATC	Tool capacity	pc	-	-	-	-	8
	Max. tool length (Axial/radial)	mm	-	-	-	-	75/60
	Max. tool diameter	mm	-	-	-	-	Ø20
	Max. tool weight (Tool+tool shank)	kg	-	-	-	-	6
Power turret	Tool shank		VDI 40	VDI 40	VDI 40	VDI 40	KV40
	Tool capacity	pc	12	12	12	12	-
	O.D. tool	mm	25×25	25×25	25×25	25×25	25×25
	I.D. tool	mm	Ø40	Ø40	Ø40	Ø40	Ø32
	Max. speed	rpm	6000	6000	4500	4500	3000
	Spindle motor	kw	5.5/3.7	5.5/3.7	5.5/3.7	5.5/3.7	5.5/3.7
	Max. tool diameter	mm	Dia. 20/M16	Dia. 20/M16	Dia. 20/M16	Dia. 20/M16	Dia. 20/M16
	Index time	sec	0.6	0.6	0.6	0.6	1.0
	Driving system		Servo	Servo	Servo	Servo	Servo
Feed	X/Y/Z/B axis stroke	mm	230/±51/600/-	230/±51/600/600	260/±51/600/-	260/±51/600/700	360/±51/660
	X/Y/Z/B axis rapid traverse	m/min	24/15/30/-	24/15/30/24	24/15/30/-	24/15/30/24	24/15/30
	Cutting feedrate	mm/rev	0.001-500	0.001-500	0.001-500	0.001-500	0.001-500
Tailstock	Tailstock stroke	mm	600	-	700	-	700
	Tailstock taper		MT#5	-	MT#5	-	MT#5
	Center diameter	mm	Ø56	-	Ø90	-	Ø90
	Driving system		Hydraulic	-	Hydraulic (opt. servo)	-	Hydraulic (opt. servo)
Hydraulic unit	Hydraulic tank capacity	L	30	30	30	30	30
	Hydraulic motor	kw	1.5	1.5	2.2	2.2	1.5
Coolant unit	Coolant tank capacity	L	160	160	170	170	170
	Coolant motor	kw	0.55	0.55	0.37	0.37	0.37
Motor	Spindle motor (50% ED)	kw	11/9	11/9	15/11	15/11	15/11
	Sub-spindle motor (50% ED)	kw	-	7.5/5.5	-	7.5/5.5	-
	X/Y/Z/B axis servo motor	kw	2.5/1.8/2.5/-	2.5/1.8/2.5/1.8	4.0/1.6/3.0/-	4.0/1.6/3.0/1.6	4.0/1.6/3.0
Machine size	L×W×H	mm	2800×1940×2210	3200×2010×2210	3150×2160×2330	3400×2190×2330	3150×2100×2390
	Weight	kg	4800	5100	6200	6300	6800



Bar feeder



Part catcher



Tri-color warning light



Oil mist collector



Transformer



Sub-operation box

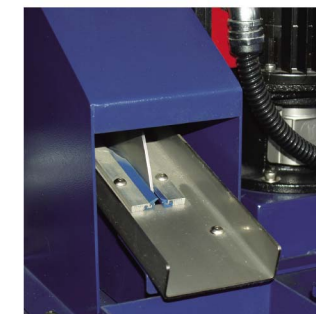

Oil skimmer



A/C for electrical cabinet



Tool presetter

Machine Dimensions

Unit:mm

TB-20Y [TB-20YB]

■ Front view

■ Side view

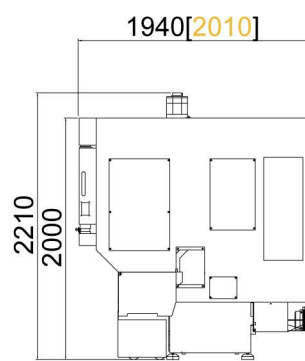
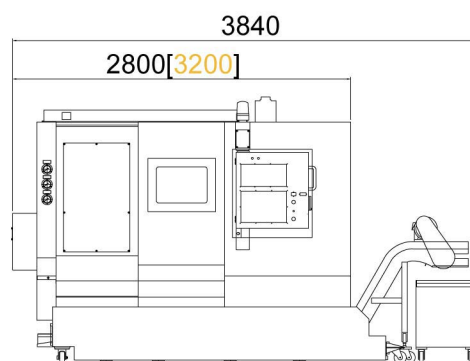

TB-25Y [TB-25YB]

■ Front view

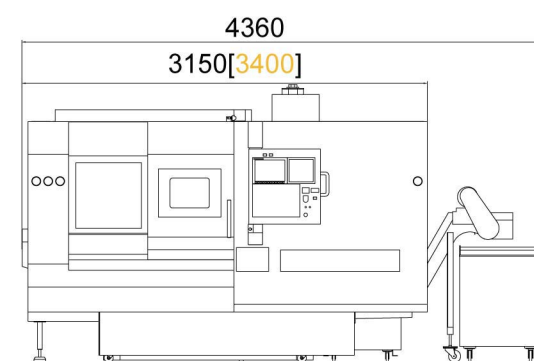

TB25Y-ATC

■ Side view

■ Front view

■ Side view

