

Machine dimensions

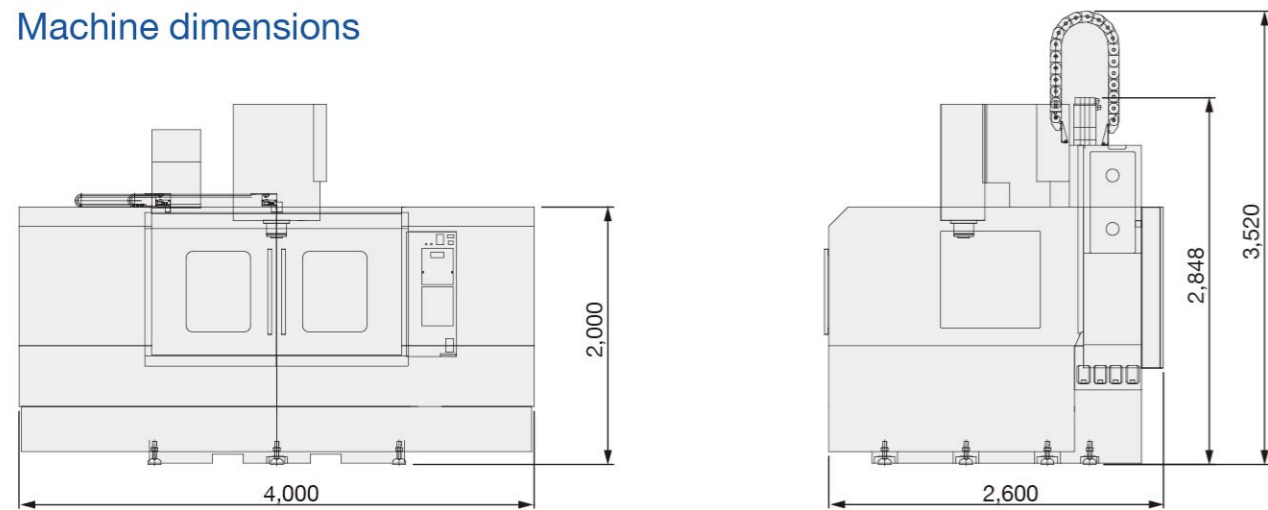

Unit : mm

Specification

Item	Specification	Unit	TMV-1500A (#40)	TMV-1500A (#50)
Table	Table size (L×W)	mm	1,600×762	
	Max. table load	kg	1,869	
	Table height from floor	mm	950	
	T-slot (size×No.)	mm	18×7	
Spindle	Spindle taper		7/24 Taper No.40	7/24 Taper No.50
	Spindle speed		Belt-driven type 8,000 (opt. 10,000)	Belt-driven type 6,000 (opt. 3,500)
Stroke	X/Y/Z axis stroke	mm	1,525/762/710	
	Spindle nose to table	mm	100-810	
Feed	X/Y/Z axis rapid traverse	m/min	18/18/18	
	Cutting feedrate	mm/min	1~10,000	
ATC	Tool shank		BT-40 (Opt. CAT-40)	BT-50 (Opt. CAT-50)
	Tool capacity	pc	24 (Opt. 30)	24 (Opt. 32)
	Max. tool diameter	mm	Ø89	Ø110
	Max. tool diameter (w/o adjacent tool)	mm	Ø125	Ø200
	Max. tool length	mm	250	300
	Max. tool weight	kg	7	15
Motor	Spindle motor	kW	7.5/9 (11/15/18.5)	11/15
	X/Y/Z servo motor	kW	3.0/4.0/7.0	
	Coolant motor	kW	0.37	
Controller	FANUC 0i-M			
Machine size	W×L×H	mm	4,000×2,600×3,520	
	Weight	kg	13,000	13,500

©specifications may be changed without prior notice

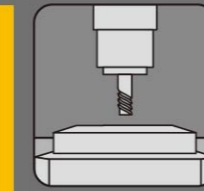

TMV-1500A

Vertical Machining Center



Tongtai Tongtai Machine & Tool Co., Ltd.

Headquarters

No.3, Luke 3rd Rd., Luzhu Dist., Kaohsiung City 82151, Taiwan
 TEL : 886-7-9761588
 FAX : 886-7-9761589, 886-7-9761590
 Website : www.tongtai.com.tw

Taoyuan Office	TEL : 886-3-4551399	FAX : 886-3-4559730
Taichung Office	TEL : 886-4-23589600	FAX : 886-4-23589993
Japan Branch	TEL : 81-4-71438355	FAX : 81-4-71438360
Europe Branch	TEL : 31-161-454639	FAX : 31-161-454768
Malaysia Branch	TEL : 603-78597113	FAX : 603-78597115
Vietnam Office	TEL : 84-4-62766090	
Thailand Office	TEL : 66-2-7443440	FAX : 66-2-3986518
Indonesia Office	TEL : 62-21-45850875	FAX : 62-21-45850876

Affiliates

Honor Seiki Co., Ltd.

TEL: 886-7-9759888
 FAX: 886-7-9759999
 Website : www.honorseiki.com.tw

Asia Pacific Elite Corp.

TEL: 886-4-23589313
 FAX: 886-4-23588913
 Website : www.apecnc.com

China Operation Center

Shuzhou Tong-yu Machine & Tool Co., Ltd.

No.555 Huahong Road, Economic Development Zone,
 Songling Town, Wujiang City, Jiangsu Province, China
 TEL : 86-512-63430168
 FAX : 86-512-63431622
 E-mail : sales@tong-yu.com.cn

Wuhan Branch	TEL : 86-27-59409109	FAX : 86-27-59409110
Chongqing Branch	TEL : 86-23-67865925	FAX : 86-23-67867717
Guandong Branch	TEL : 86-755-27222119	FAX : 86-755-27222115
Tianjin Branch	TEL : 86-22-24417640	FAX : 86-22-24416738
Shanghai Office	TEL : 86-21-24208138	FAX : 86-21-34073262
Shenyang Office	TEL : 86-24-24142968	FAX : 86-24-24115782

Quick-Tech Machinery Co., Ltd

TEL: 886-6-3841155
 FAX: 886-6-3841177
 Website : www.quicktech.com.tw



TMV-1500A

Spindle

Available in both 40 and 50 tapers, the grease lubricated cartridge spindles are liquid cooled. The spindle cooler reduces thermal deformation and extends spindle life. Standard 8,000 rpm belt-driven 40 taper spindle can optionally be changed to 10,000 rpm for high speed machining. Furthermore, BT-50 6,000 rpm, 3,500 rpm belt-driven spindle are also available for heavy cutting.



	40 taper		50 taper	
	8,000 rpm	10,000 rpm	6,000 rpm	3,500 rpm
Max. speed	8,000 rpm	10,000 rpm	6,000 rpm	3,500 rpm
Horse power	9/7.5 kW	18/15/11 kW	15/11 kW	15/11 kW
Torque	114/95 Nm	44/36/26 Nm	191/140 Nm	239/175 Nm

Belt-driven 8,000 rpm (40 taper) (Standard)

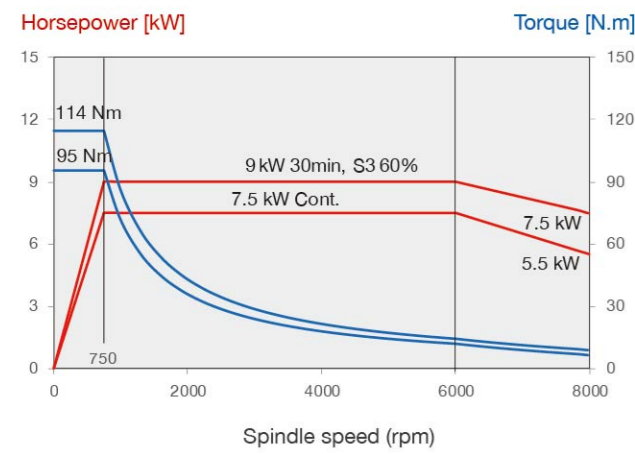

Belt-driven 10,000 rpm (40 taper) (Optional)



Belt-driven 6,000 rpm (50 taper) (Optional)

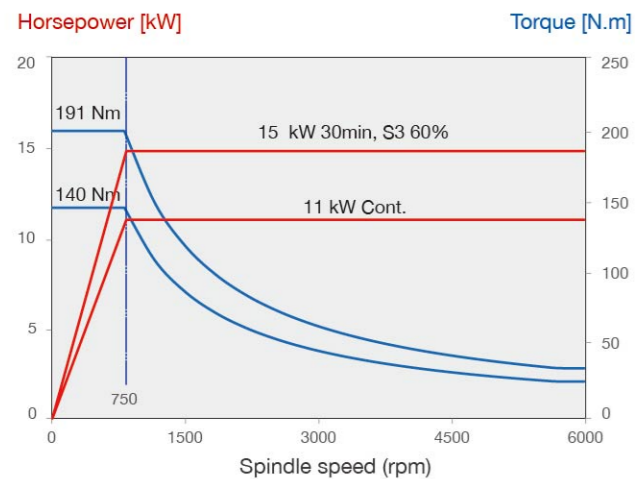

Belt-driven 3,500 rpm (50 taper) (Optional)

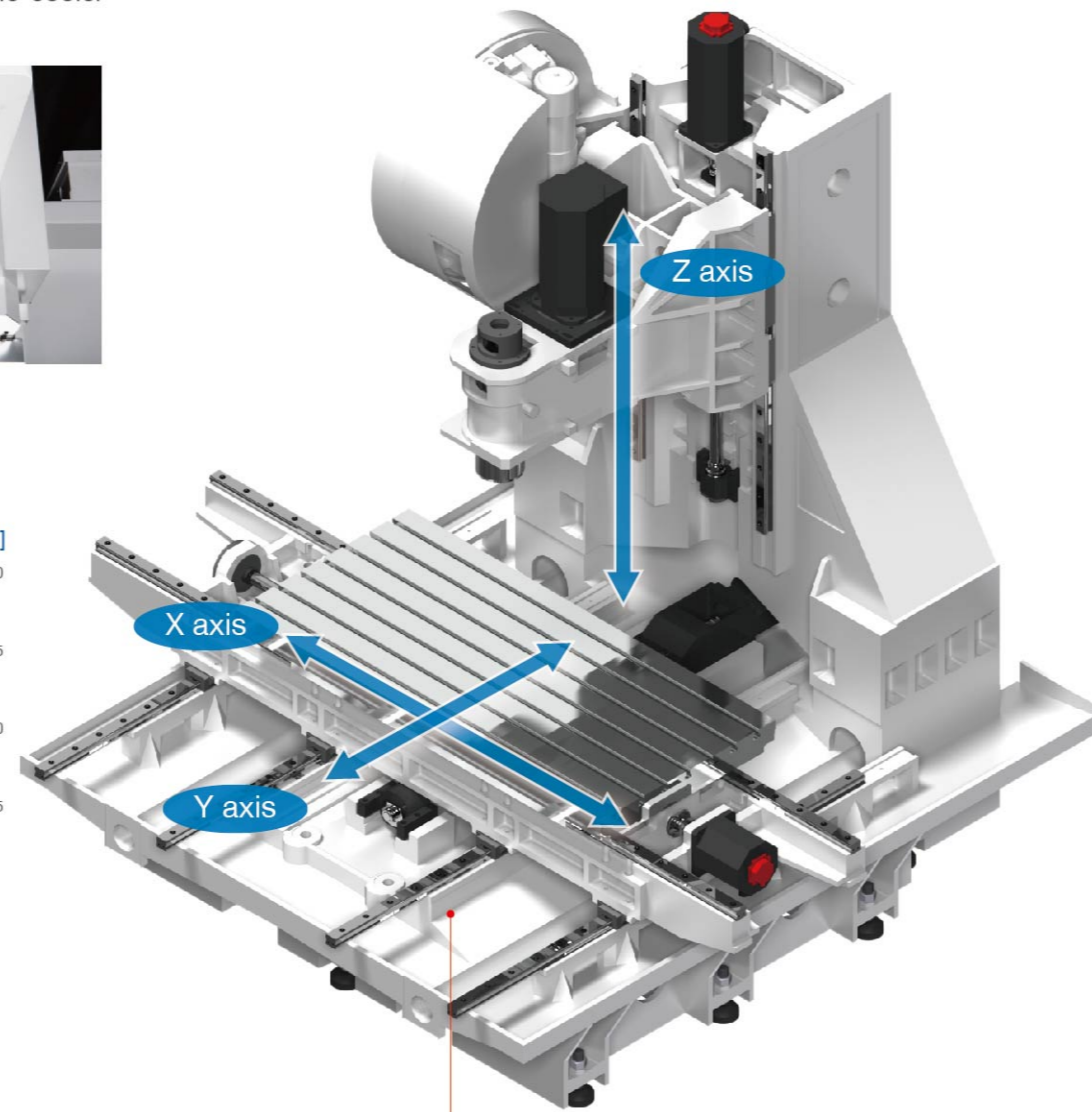
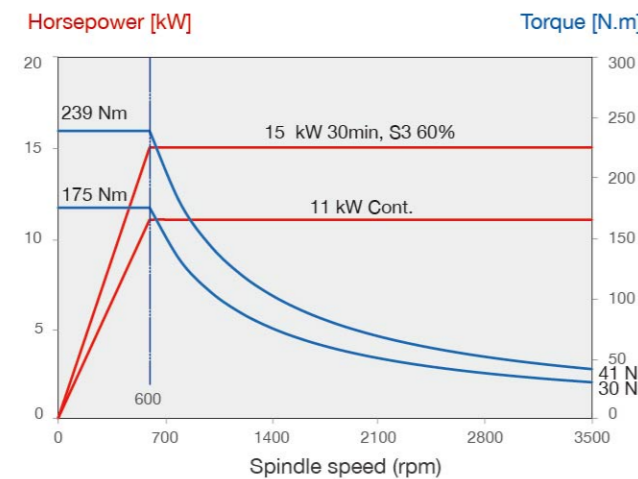

Casting components on this machine are made of high quality cast iron, and through finite element analysis (FEA), the static and dynamic rigidity can be ensured.

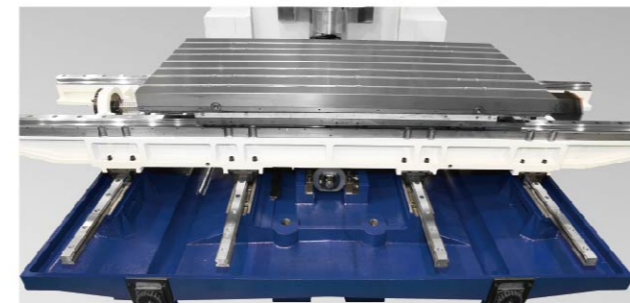

The Y axis employs four guideways to offer superior support of the X axis saddle and best accuracy.

Stroke

X/Y/Z axis 1,525/762/710 m/min

Rapid traverse

X/Y/Z axis 18/18/18 m/min

ATC

The cam-type tool changer has higher accuracy and lower noise. In addition, the stable tool clamping can ensure spindle accuracy and expand bearing life.

	40 taper	50 taper
T to T	3.0 sec	5.1 sec
Tool capacity	24 tools 30 tools (Optional)	24 tools 32 tools (Optional)

Working area

Table size 1,600 mm × 762 mm
Max. load 1,869 kg

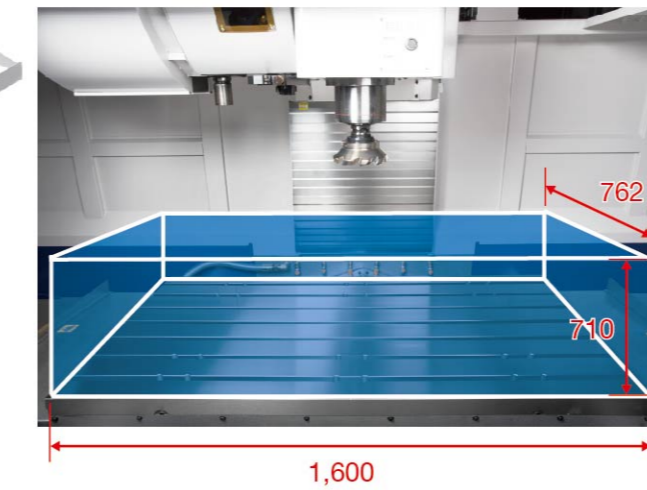

Chip disposal

Equipped with two chip augers and flushing system, even heavy chip loads are evacuated efficiently.



Operation

With the door opened, the top side is wide open, providing a wide space for loading work.

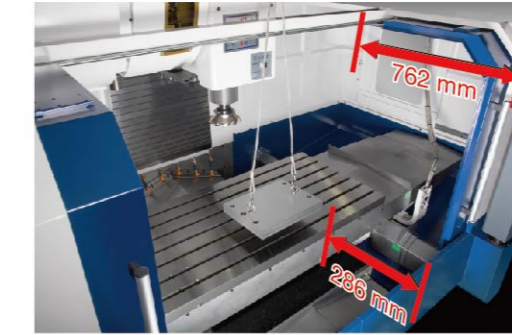

The distance and height of table are very ergonomic. It provides the operator a very comfortable and convenient working area.



Maintenance

The wide door opening provides a spacious area for the operator during operation and processing maintenance.

Door opening width 1,664 mm

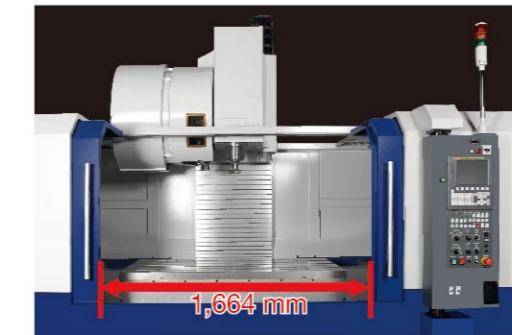

Pneumatic units, lubricant pump, and some maintenance items are located on the rear side of machine, with easy access.



Standard/Optional accessories

	Standard	Optional
Tool Shank	BT-40 CAT-40 BT-50 CAT-50	<input checked="" type="radio"/> <input type="radio"/> <input type="radio"/> <input type="radio"/>
Coolant through spindle pump	15 bar 40 bar 70 bar	<input type="radio"/> <input type="radio"/> <input type="radio"/>
Cooling system	Spindle coolant system Hydraulic temperature control system Coolant temperature control system Air conditioner for electrical cabinet	<input type="radio"/> <input type="radio"/> <input type="radio"/> <input type="radio"/>
Chip conveyor	Two chip augers Bed flushing pump Scraper type conveyor Magnetic scraper type conveyor Hinge type conveyor	<input checked="" type="radio"/> <input checked="" type="radio"/> <input type="radio"/> <input type="radio"/> <input type="radio"/>

	Standard	Optional
Lubrication system	General lubrication system LHL integrated lubrication system	<input checked="" type="radio"/> <input type="radio"/>
Positioning accuracy system	Three axes linear scale 5μ resolution Three axes linear scale 3μ resolution Three axes magnetic scale 5μ resolution	<input type="radio"/> <input type="radio"/> <input type="radio"/>
Tool measuring system	Tongtai made touch type tool breakage detector Laser type tool measurement	<input type="radio"/> <input type="radio"/>
4th axis rotary table		<input type="radio"/>
Others	Workpiece measuring device Machining air blow Air gun Coolant gun Oil skimmer Oil mist collector Automatic door	<input type="radio"/> <input type="radio"/> <input type="radio"/> <input type="radio"/> <input type="radio"/> <input type="radio"/> <input type="radio"/>
Controller	FANUC 0i-M FANUC 31i-M	<input checked="" type="radio"/> <input type="radio"/>