

## Examples of Machining

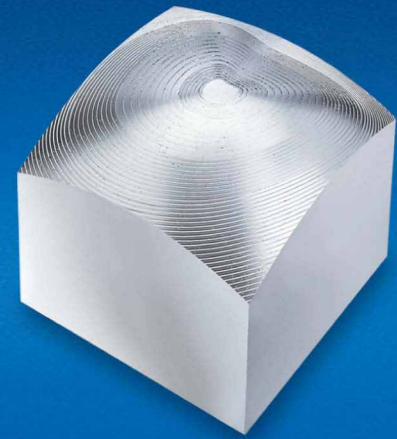

### Lamp mold

Tool : 0.1R ball nose end mill  
Speed : 20000 rpm  
Feedrate : 1000 mm/min  
Machining time : 9.8 hr  
Material : NAK80、HRC 40°  
Workpiece size : 120×120×80 mm



### Cellphone mold

Tool : 0.3R ball nose end mill  
Speed : 18000 rpm  
Feedrate : 1200mm/min  
Machining Time : 5.4hr  
Material : NAK80、HRC 40°  
Workpiece size : 80×180×50 mm

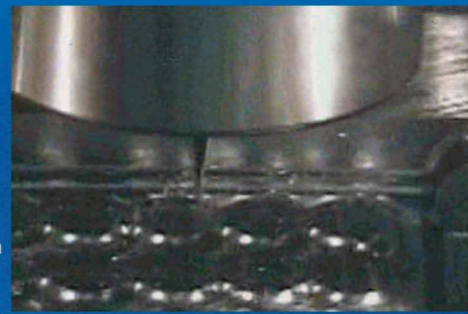

### Fan mold

Machining time : 5.75 hr  
Material : NAK80、HRC 40°



### Forging mold

Machining time : 4.8 hr  
Material : SKD61、HRC 52°  
Workpiece size : 100×100×35 mm

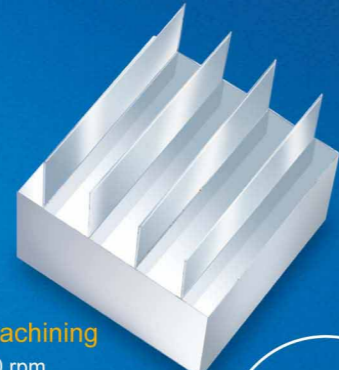

### Thin wall machining

Speed : 20000 rpm  
Feedrate : 8000mm/min  
Material : AL 7075  
The well : 0.4/0.3/0.2/0.1 mm

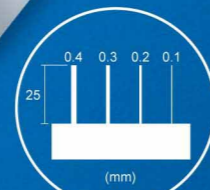

### Crankshaft mold

Tool : Ø3 ball nose end mill  
Speed : 13000 rpm  
Feedrate : 2200 mm/min

Finishing time : 1.2 hr  
Material : SKD11、HRC 60°  
Workpiece size : 80×50×30 mm



### Connecting rod

Material : NAK80(HRC40)  
Workpiece size : 300×180×40 mm  
Machining time : 4.5 hr

## MDV-812 Standard Specifications

Item	Specification	Unit	MDV-812
Table	Working area (LxW)	mm	1300×800
	Max. load capacity	kg	2000
	Table height from floor	mm	850
	T-Slots (size x No.)	mm	18×7
Spindle	Spindle nose		7/24 Taper No. 40 (HSK-63A)
	Spindle speed	rpm	12000 (Opt. 20000)
	Spindle bearing diameter	mm	Ø75
Stroke	X/Y/Z axis stroke	mm	1200/800/500
	Spindle nose to table	mm	150-650
Feed	X/Y/Z rapid traverse	m/min	30/30/30
	Cutting feedrate	mm/min	1-10000
ATC	Tool shank		BT-40 (Opt. HSK-63A)
	Tool capacity	pc	16 (Opt. 40)
	Max. tool diameter	mm	16 Tools : Ø125 / 40 Tools : Ø70
	Max. tool length	mm	300
	Max. tool weight	kg	8
Motor	Spindle motor (50% ED)	kw	22/18.5 (Opt. 45/30)
	X/Y/Z servo motor	kw	7.0/7.0/7.0
	Coolant motor	kw	0.37×2
Machine	L×W×H	mm	3350×4390×3370
	Weight	kg	13000

©SPECIFICATIONS MAY BE CHANGED WITHOUT PRIOR NOTICE

### Standard accessories

- Spindle speed 12000 rpm
- Spindle nose BT-40
- Air blower unit
- Rigid tapping
- Halogen
- Coolant unit
- Automatic lubrication equipment
- Door interlock unit
- Spindle cooler unit
- Spindle load meter
- Workpiece counter
- Fanuc Oi-M

### Optional accessories

- Spindle speed 20000 rpm
- Spindle nose HSK-A63
- Transformer / stabilizer
- Auto door
- Fully enclosed splash guard
- Liner scale
- Coolant through spindle
- Tool length automatic measuring unit
- Tool life management
- Tool breakage detector
- Function modular package A
- Function modular package B
- Oil skimmer / oil & mist collector
- Chip conveyor / chips tank
- 4th axis function
- A/C for electrical cabinet
- M code
- Auto power off
- Sub operation box

### Machine Dimensions

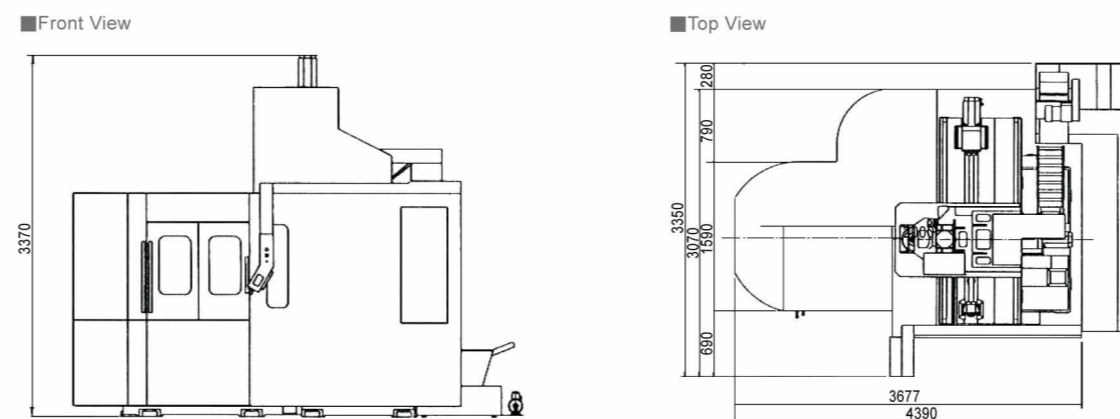

## Tongtai Machine & Tool Co., Ltd.

• HEAD OFFICE  
NO.3, LUKE 3rd RD., LUZHU DISTRICT, KAOHSIUNG CITY, 82151, TAIWAN.  
TEL : 886-7-9761588 FAX : 886-7-9761589/886-7-9761590  
Website : <http://www.tongtai.com.tw>

• TAICHUNG OFFICE TEL : 886-3-4551399 FAX : 886-3-4559730

• TONGTAI SEIKI U.S.A INC. TEL : 1-845-2675500 FAX : 1-845-2675546

• TONGTAI MACHINE & TOOL JAPAN CO., LTD. TEL : 81-4-71438355 FAX : 81-4-71438360

• TONGTAI SEIKI VIETNAM LIMITED TEL : 84-435112529

• EUROPE OFFICE TEL : 31-161-454639 FAX : 31-161-454768

• THAILAND OFFICE TEL : 66-2-7443440 FAX : 66-2-3986518

• INDONESIA OFFICE TEL : 62-21-45850521 FAX : 62-21-45840522

• MALAYSIA OFFICE TEL : 60-3-78456815 FAX : 60-3-78456851

• CHINA OFFICE  
SHIJIUZHOU TONG-YU MACHINE & TOOL CO., LTD.  
TEL : 86-512-63430168 FAX : 86-512-63431622  
E-mail : [sales@tong-yu.com.cn](mailto:sales@tong-yu.com.cn)

• WUHAN OFFICE TEL : 86-27-59409109 FAX : 86-27-59409110

• SHANGHAI OFFICE TEL : 86-21-24208138 FAX : 86-21-34073262

• CHONGQING OFFICE TEL : 86-23-67865925 FAX : 86-23-67867717

• GUANGZHOU OFFICE TEL : 86-755-27222119 FAX : 86-755-27222115

• TIANJIN OFFICE TEL : 86-22-24417640 FAX : 86-22-24416738

2012.05.15 Design by Tongtai Machine & Tool Co., Ltd.



ISO 9001 ISO 14001 CE  
A Worldwide Tradition of Quality Products and Customer Service

# MOLD & Die Milling Series MDV-812

High ■Quality ■Precision ■Efficiency ■Economy



Tongtai Machine & Tool Co., Ltd.

Trust & Technology

# MDV-812 Vertical Column Type Machining Center

- Reduce machining processes and delivery time.
- Give perfect surface accuracy finishing and save the time for further polishing.
- Capable to machine material with hardness above HRC 40°. The time of EDM could reduce by means of small diameter ball nose endmill to clean up corner.
- Excellent in machining aerospace industrial alloy, light and thin wall work pieces.

- X/Y/Z stroke=1200/800/500 mm
- X/Y/Z rapid traverse=30m/30m/30 m/min
- Max. load capacity=2000 kg
- Machine size (W×L×H)=3350×4390×3370 mm
- Machine weight=13000 kg

- High rigidity and double wall machine structure design ensures accuracy and stability during high speed machining.
- High grade cast steel machine bed with annealing for stress relieving before any machining process. This approves the long-term accuracy and stability.

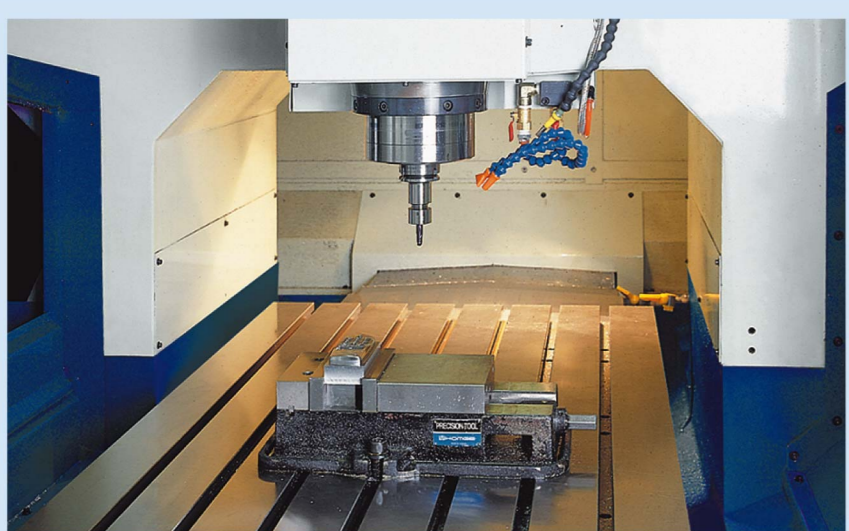

- Linear guide ways are high preloaded, high rigidity designed and using roller type bearing



- ATC 16 Tools/40 Tools (Opt.)
- BT-40/HSK-63A (Opt.)



- Rigid type coupling Ensure  $\mu\text{m}$  fine feeding and no backlash accuracy.



- Ball screw Use preloaded mechanism to reduce effect upon thermal expansion during machining.



- Dual screw type chip conveyor design provides excellent chip disposal.



## Spindle output and torque chart

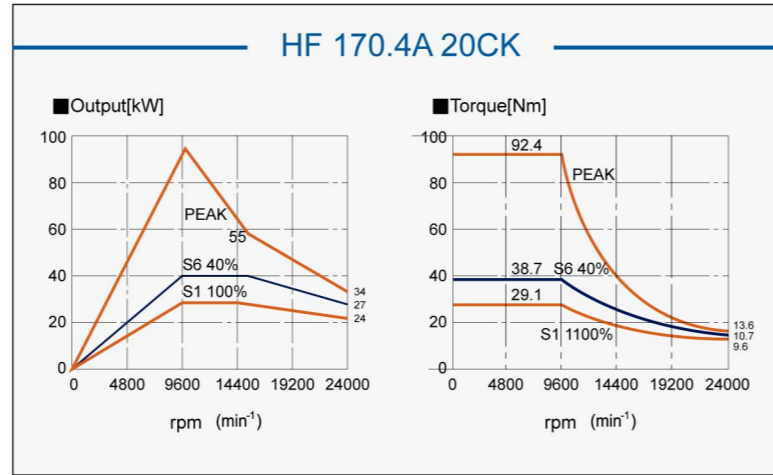

## FANUC $\alpha$ B112L-18.5(BT-40 12000 rpm)

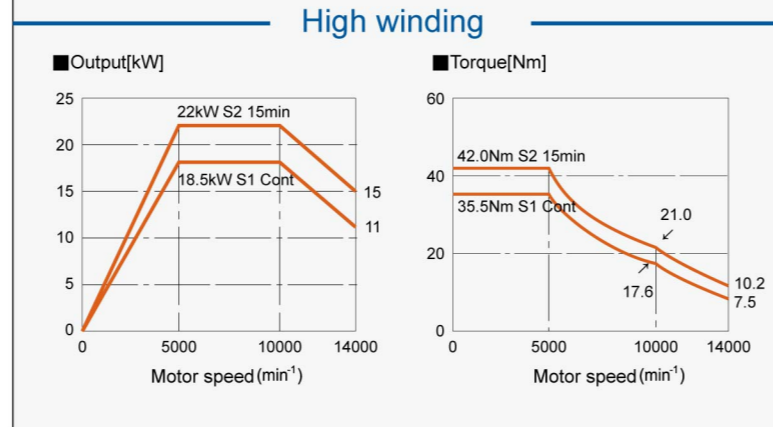
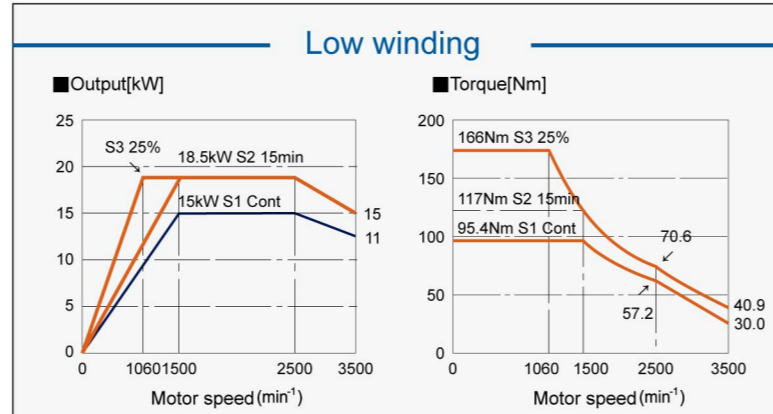

## Controller FANUC 0i-M (Standard) / SIEMENS 840D (Optional)



- High precision of B function (Opt.)
- Data. Server with ATA flash card.
- DNC operation through PCMCIA port.
- Servo HRV<sub>3</sub> control
- AI Nano HPCC.
- Look-ahead blocks 600.

## Electrical cabinet



Air conditioner for internal temperature control (Optional)

## Spindle



### Powerful spindle 12000 rpm

- 18.5/22kW
- 7/24 Taper No.40
- High grade grease lubrication

Reinforced pull stud mechanism : Lengthen the accuracy and lifetime of spindle bearings.

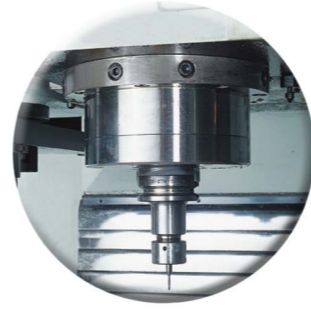

### High Speed 20000 rpm (Opt.)

- 30/45 kW
- BBT-40/HSK-63A
- Oil mist lubrication.



### Spindle cooling system

## Performance and accuracy test

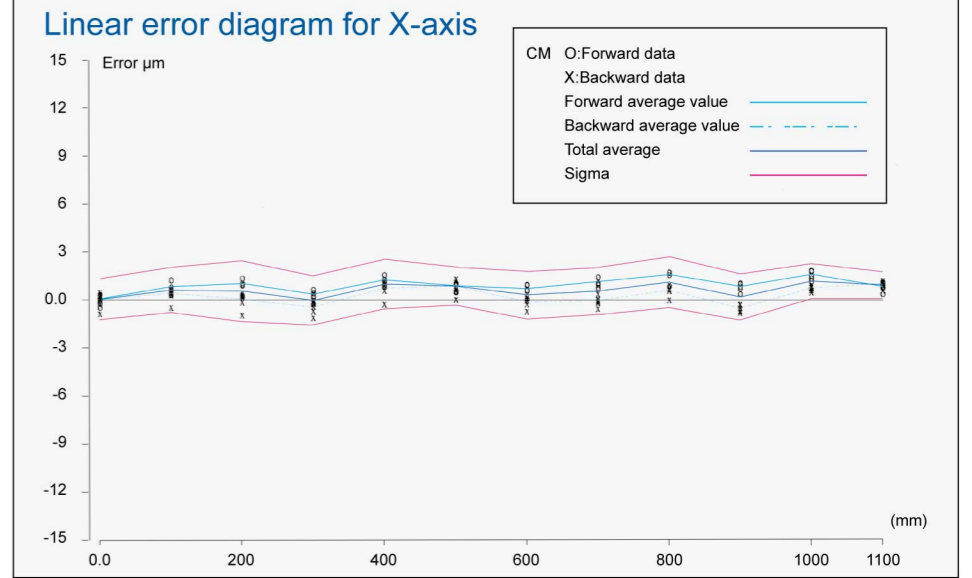

	Positioning accuracy	Repeatability
VDI3441 (Germany)	0.01 mm Fully Stroke	$\pm 0.003$ mm

Numerical analysis

P : P Infinite :	4.222 $\mu\text{m}$
Accuracy F :	3.600 $\mu\text{m}$
Accuracy R :	4.039 $\mu\text{m}$
Ps : P diffuse :	2.823 $\mu\text{m}$
Ps : Average :	2.110 $\mu\text{m}$
Pa : P DEV :	1.225 $\mu\text{m}$
Rs+U : Repeatability :	3.776 $\mu\text{m}$
Original accuracy :	2.946 $\mu\text{m}$
Original accuracy :	2.306 $\mu\text{m}$
Original accuracy :	2.411 $\mu\text{m}$
Original repeatability :	2.301 $\mu\text{m}$
Original repeatability :	1.086 $\mu\text{m}$
Original repeatability :	1.389 $\mu\text{m}$
U : Mean Rv E :	.6311 $\mu\text{m}$

Machine Name : Vertical machining center  
File date and time : 2001/08/13 09:20:09 AM  
Plant : TONGTAI  
Machine Type : MDV-812

Environment data

	Min.	Max.	Average
Temp	29.05	29.26	29.16
Pressure	756.76	756.83	756.79
Air humidity	75.0	75.0	75.0
MT1 temp.	30.82	30.88	30.85
MT2 temp.			
MT3 temp.			

Expansion coefficient : 11.7 rpm/°C

THP TR265 Version 3.29

LS ROUNDNESS RESULTS

Feature name	11174
Feature no.	02
R	53.873 mm
O	5.60 $\mu\text{m}$
E	0.98 $\mu\text{m}$
$\angle$	140.6 deg
$\sphericalangle$	6.16 $\mu\text{m}$
Scale	2.00 $\mu\text{m}$
Z height	112.9 $\mu\text{m}$
Datum	SPINDLE
Filter type	2CR
Filter	1-500 $\mu\text{m}$
Profile	100.0%
Meas. Mode	External
Meas. Date	19-04-2000
Meas. Time	08:52:59

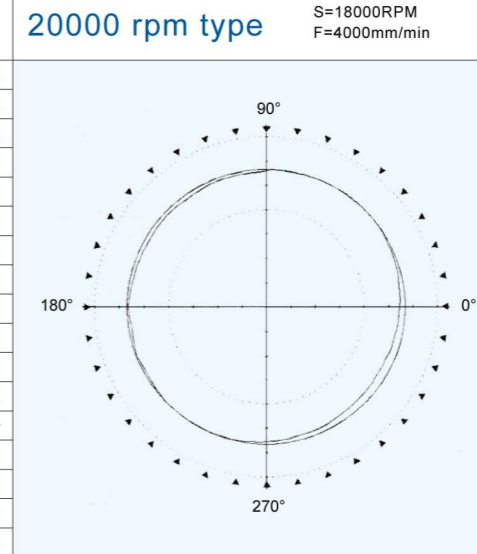

THP TR265 Version 3.29

MC ROUNDNESS RESULTS

Feature name	10658
Feature no.	05
R	105.67 mm
O	4.50 $\mu\text{m}$
E	1.17 $\mu\text{m}$
$\angle$	218.6 deg
$\sphericalangle$	4.23 $\mu\text{m}$
Scale	10.00 $\mu\text{m}$
Z height	40.9 $\mu\text{m}$
Datum	SPINDLE
Filter type	2CR
Profile	100.0%
Meas. Mode	External

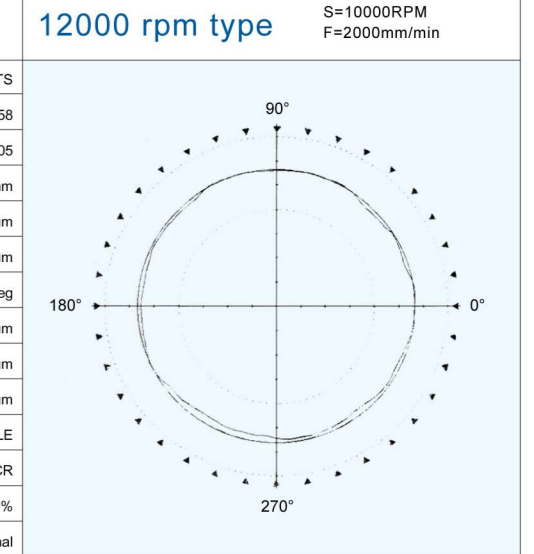

### End milling circular differential accuracy



AL 7075

### The position accuracy for boring and hole differential

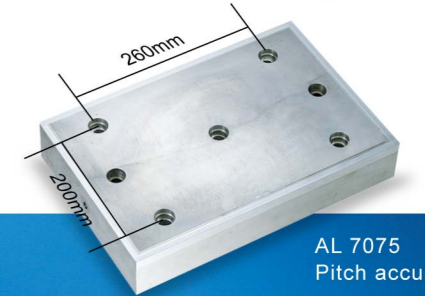

AL 7075 Pitch accuracy 0.0075 $\mu\text{m}$