

Trust & Technology

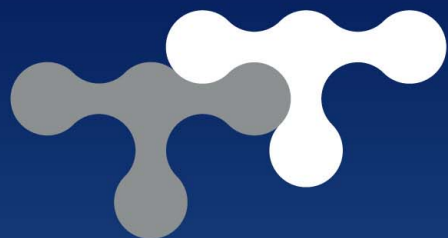

Tongtai

ISO 9001 ISO 14001 CE

A Worldwide Tradition of Quality Products and Customer Service

**HIGH SPEED/HIGH FLEXIBILITY
HORIZONTAL MACHINING CENTER**

TFH-100/200 SERIES

High ■Quality ■Precision ■Efficiency

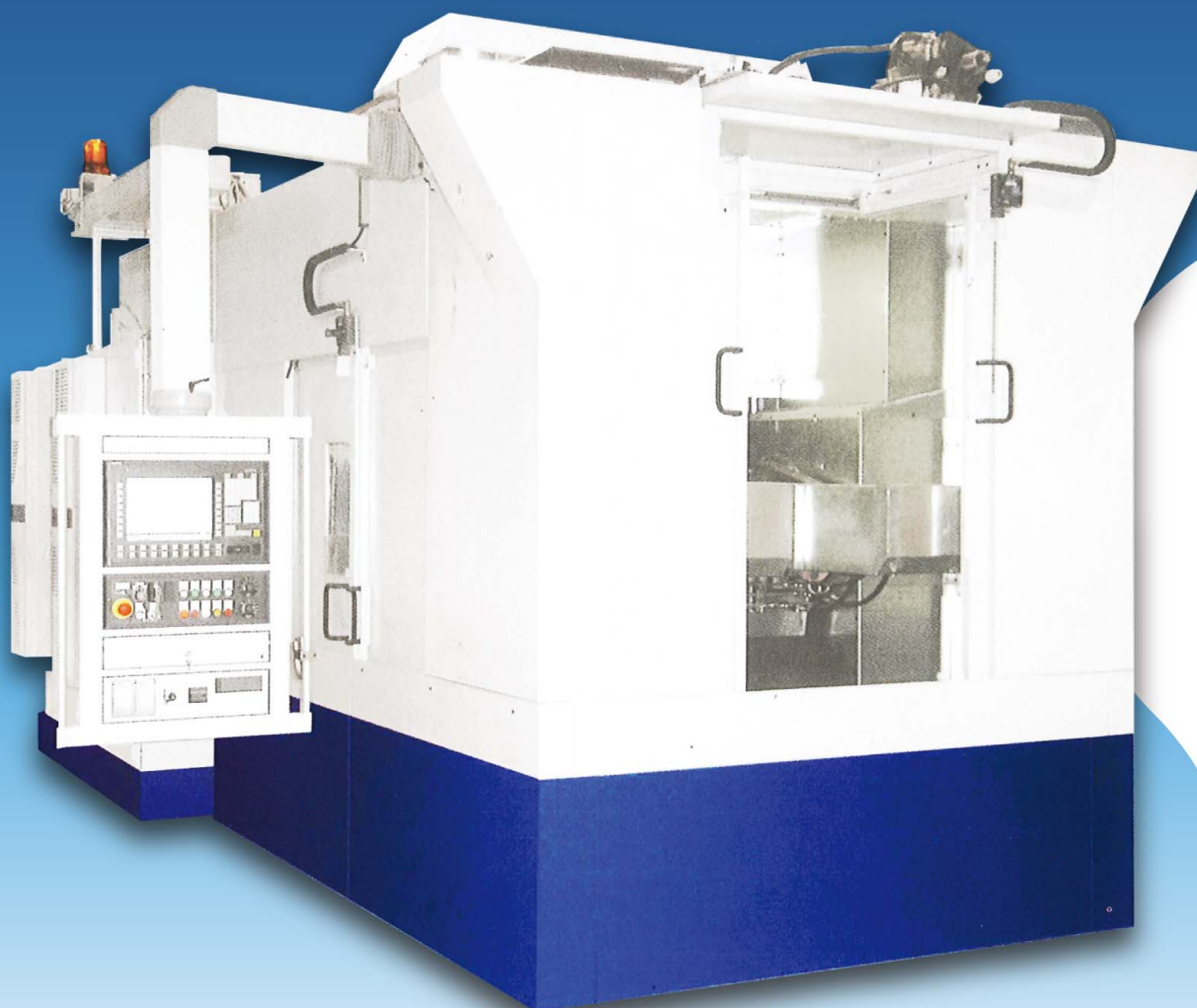

Tongtai Machine & Tool Co., Ltd.

TFH-100

Single-spindle 3-axes machining module with tool magazine

Designed as machining center or
interlinked module.

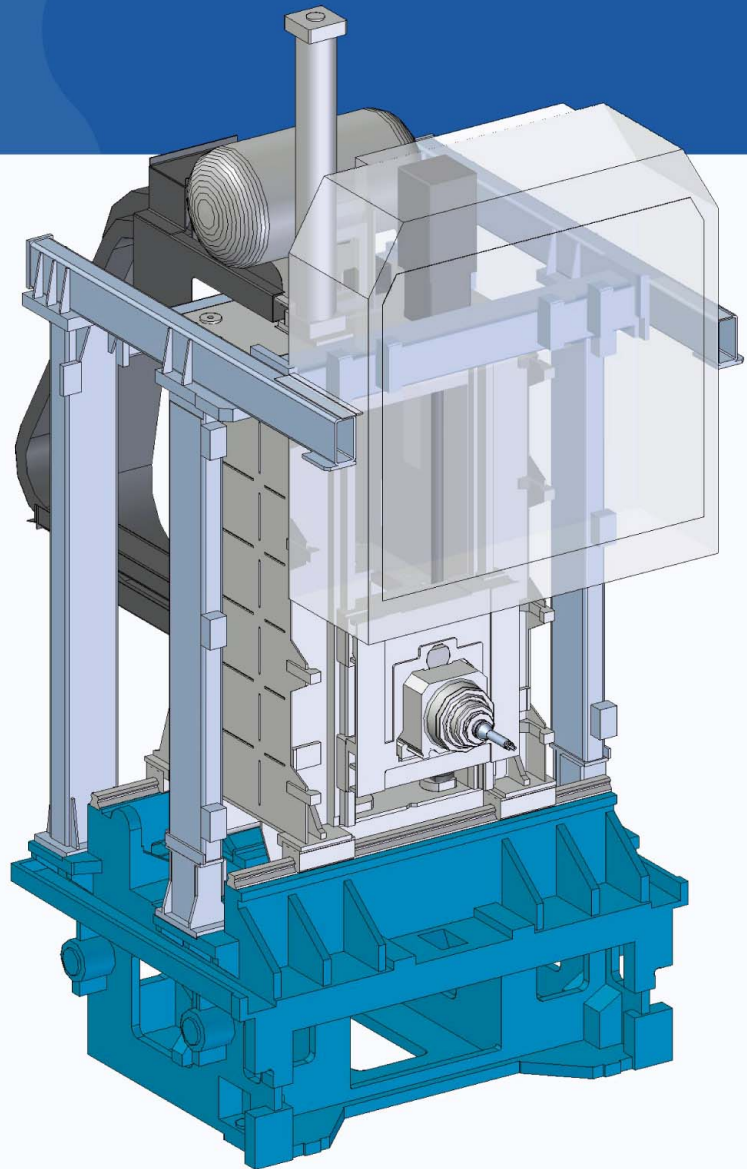
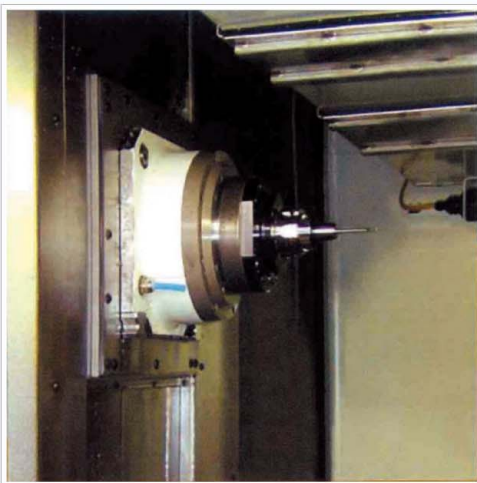

Component-side configuration

Custom design with several table variants or pallet changers, for three-, four- or five-axis machining

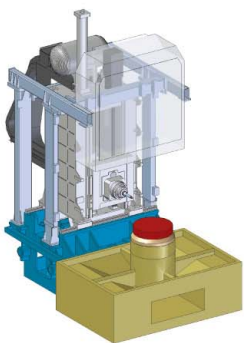

TFH-100B
Rotary table
(B-axes)

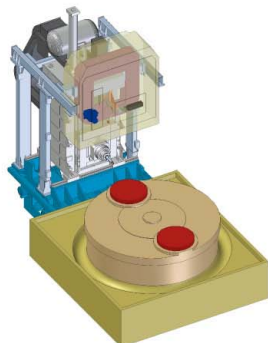

TFH-100BP
Rotary table (B-axis) with
pallet changer and
loading/unloading station

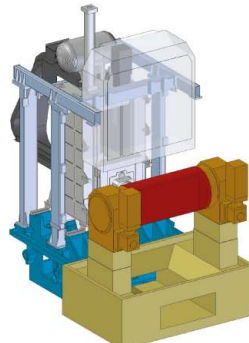

TFH-100A
Swivel beam as horizontal
rotation axis (A-axis)

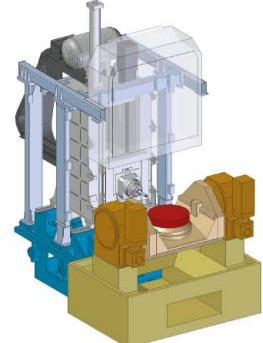

TFH-100AB
Swivel beam and rotary
table (A and B-axis) for
5-axes machining

utmost flexibility for retrofitting

Dimensioned sketch

TFH-100 with A- and B-axis tables variant

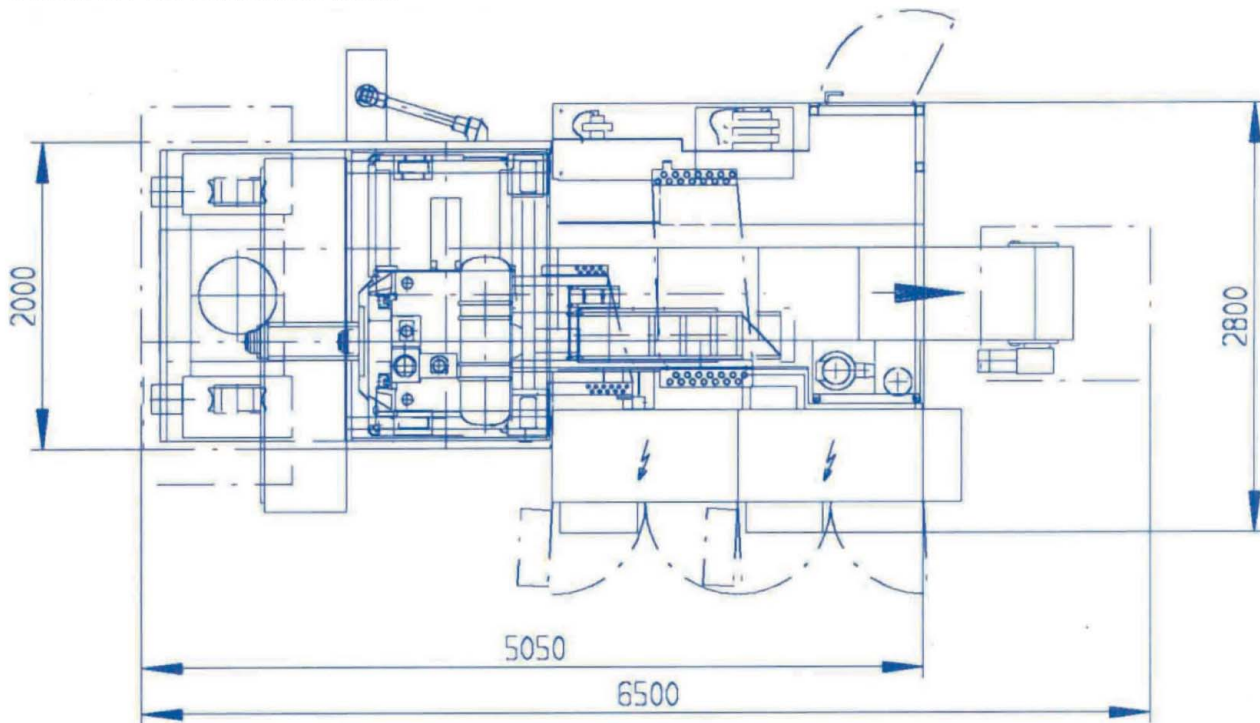

Interlinked configurations

Interlinked arrangement with overhead gantry loaders or to be included in rotary transfer machines, rotary indexing table machines and transfer lines (compatible to special-purpose subassemblies); or as stand alone machining center, as an alternative

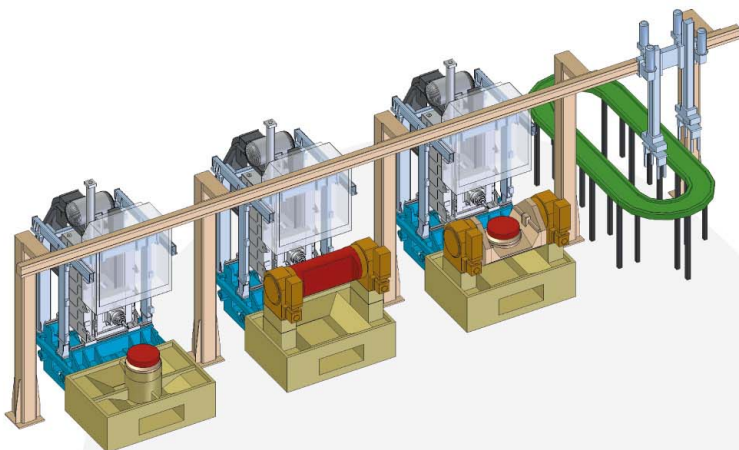

e.g. with overhead gantry loader

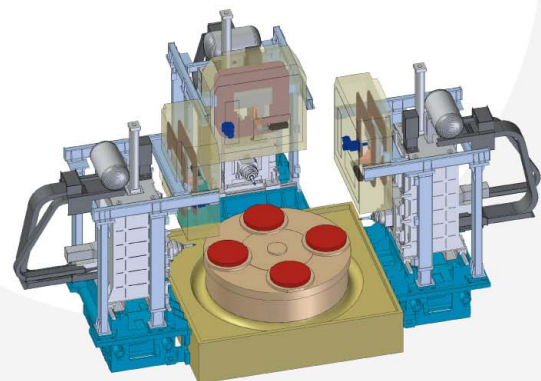

e.g. with rotary transfer system (B-axes included)

TFH-200

Twin-spindle 3-axis machining module with tool magazine

Independent travel and Positioning of
two separate Z-axes.

Designed as machining center or
interlinked module.

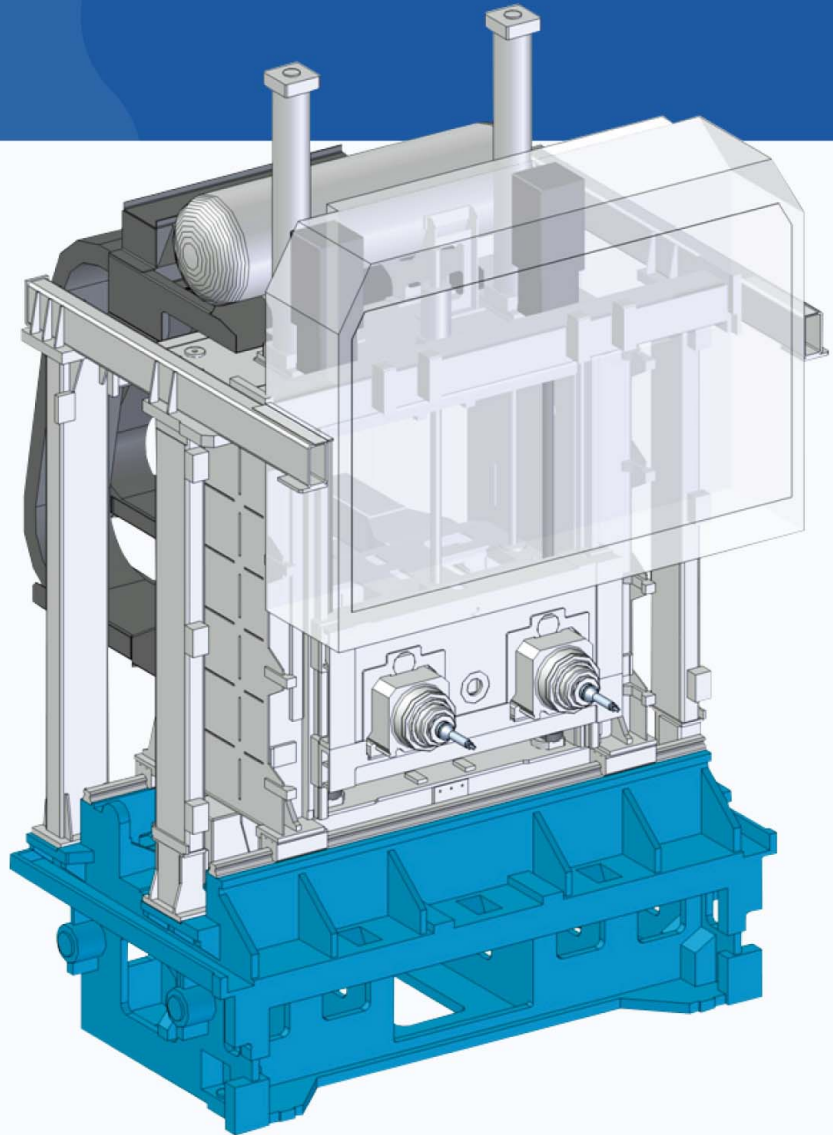
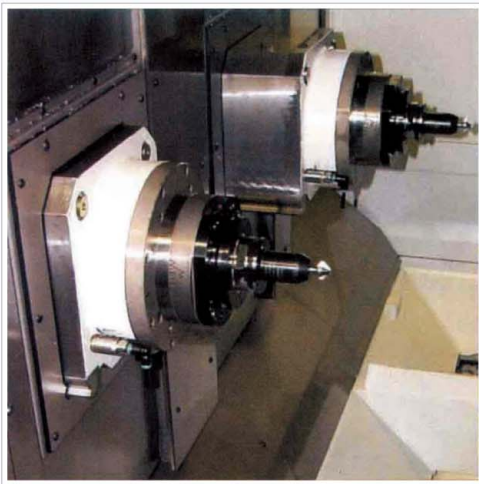

Component-side configuration

Customized design with several table variants or pallet changers, for three-, four- or five-axis machining

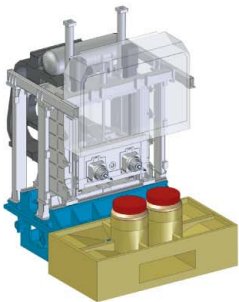

TFH-200B
Two rotary tables
(B-axes)

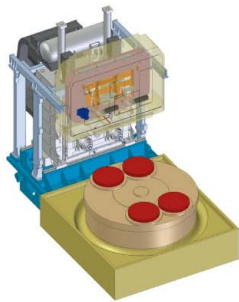

TFH-200BP
Two rotary tables (B-axes)
with pallet changer and
loading/unloading stations

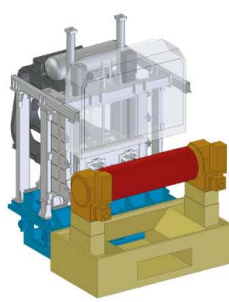

TFH-200A
Swivel beam as horizontal
rotation axis (A-axis)

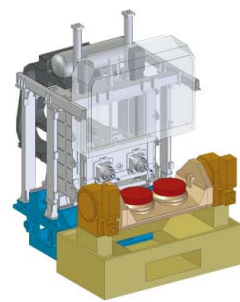

TFH-200AB
Swivel beam and two rotary
tables (A-axis + B-axes) for
5-axes machining

for topmost productivity

Dimensioned sketch(A/B-axis)

TFH-200 with swivel beam and two rotary tables

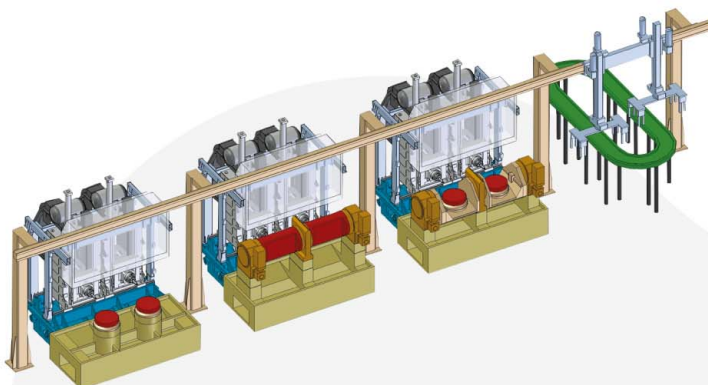
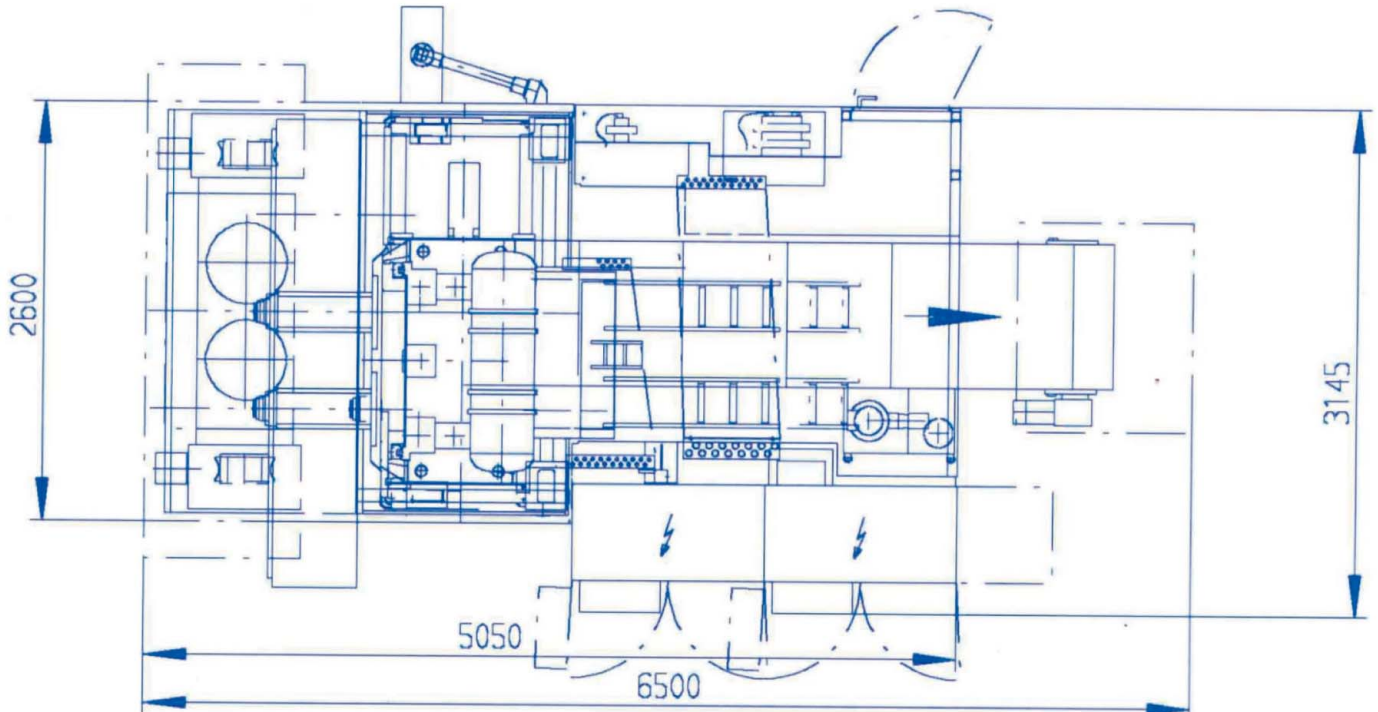

e.g. with overhead gantry loader

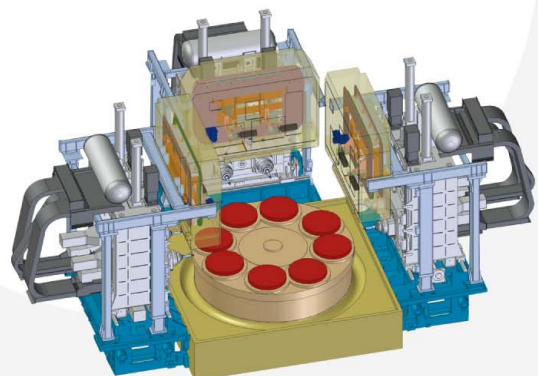

e.g. with rotary transfer system (B-axes included)

REFERENCES

Projects performed for well-known automobile manufacturers



TFH-200 center with special-purpose table assembly for 5-axis machining of crankshaft oil channels

Functions :

- Positioning for gun drilling
- Cover system for transverse drilling
- Coolant spin-off after the cutting process



TFH-200 center with special-purpose table assembly for machining of steering knuckles

Machining cell with articulated arm robot for main time-parallel component loading



TFH rotary transfer machine equipped with TFH-200 modules to machine cylinder head covers in two set-up's

Applicable in wet and dry run

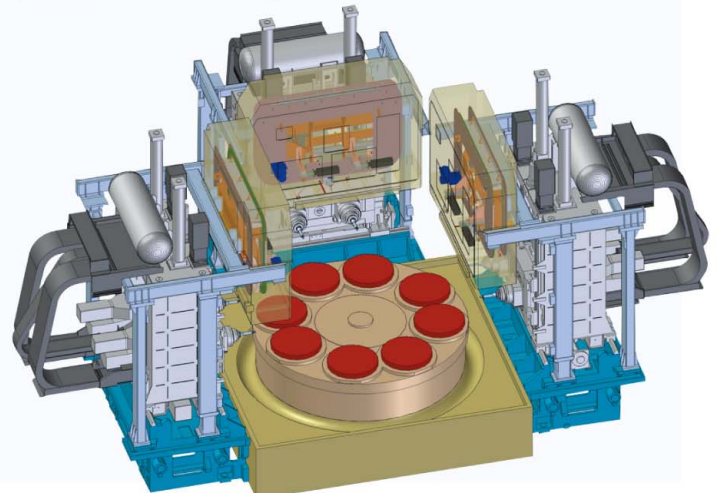

TECHNICAL SPECS

TFH-100(single-spindle machines) and TFH-200 (twin-spindle machines)

		Spindle HSK A63	Spindle HSK A80
Travel	X-axis	630 mm, option 400 / 1200 mm	630 mm, option 400 / 1200 mm
	Y-axis	600 mm, option 400 mm	600 mm, option 400 mm
	Z-axis	580 mm	580 mm
Feed	Rapid motion speed (X-axis)	600 mm	600 mm
	Rapid motion speed (Y- and Z-axis)	70 m / min	70 m / min
	Acceleration (X-axis)	80 m / min	80 m / min
	Acceleration (Y-axis)	8 m / s ²	8 m / s ²
	Acceleration (Z-axis)	10 m / s ²	10 m / s ²
Max. feed power	X-, Y- and Z-axis	15 m / s ²	14 m / s ²
Chip - to - chip - time		7500 N	8500 N
		3.5 s ²	3.7 s ²
Tools / motor spindle			
Working spindle taper (DIN 69893)		HSK-A63 (with coolant pipe)	HSK-A80 (with coolant pipe)
Spindle power (100% ED / 40% ED)		46 / 58 kw at 9880 rpm	24 / 30 kw at 9880 rpm
Speed range		20 ... 18000 rpm	20 ... 8000 rpm
Max. continuous torque (100% ED / 40% ED)		44.5 / 56 Nm	150 / 190 Nm
Spindle-to-spindle spacing in case of twin-spindle unit		600 mm	600 mm
Tool locations		5 / 36 / 60 (stand-alone machines only, not for rotary transfer)	5 / 36 / 60 (stand-alone machines only, not for rotary transfer)
for twin-spindle unit		2 × 24 / 2 × 36 (stand-alone machines only, not for rotary transfer)	2 × 24 / 2 × 36 (stand-alone machines only, not for rotary transfer)
Max. tool diameter, fully tooled		95 mm	95 mm
Tool diameter with free adjacent locations		130 mm	170 mm
Max. tool length		320 mm	320 mm
Safe tool weight per tool		8 kg	10 kg
Coolant pressure		max. 70 bar approx. 3 bar	max. 80 bar approx. 3 bar
coolant through the spindle external coolant supply			
Control		FANUC (Option SINUMERIK 840D)	

TFH for custom applications

In special-purpose machine tools, TFH modules can be combined with other machining stations. A wide spectrum of custom machining units is available to do this:

For example:



multi-spindle head



NC facing and taper turning spindles

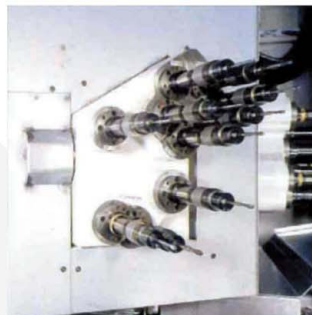

turret (automatic cutter head changer)



vertical turret head



Global Sales & Service Network

★ Head Office ● Branch ● Foreign Agency ● Factory

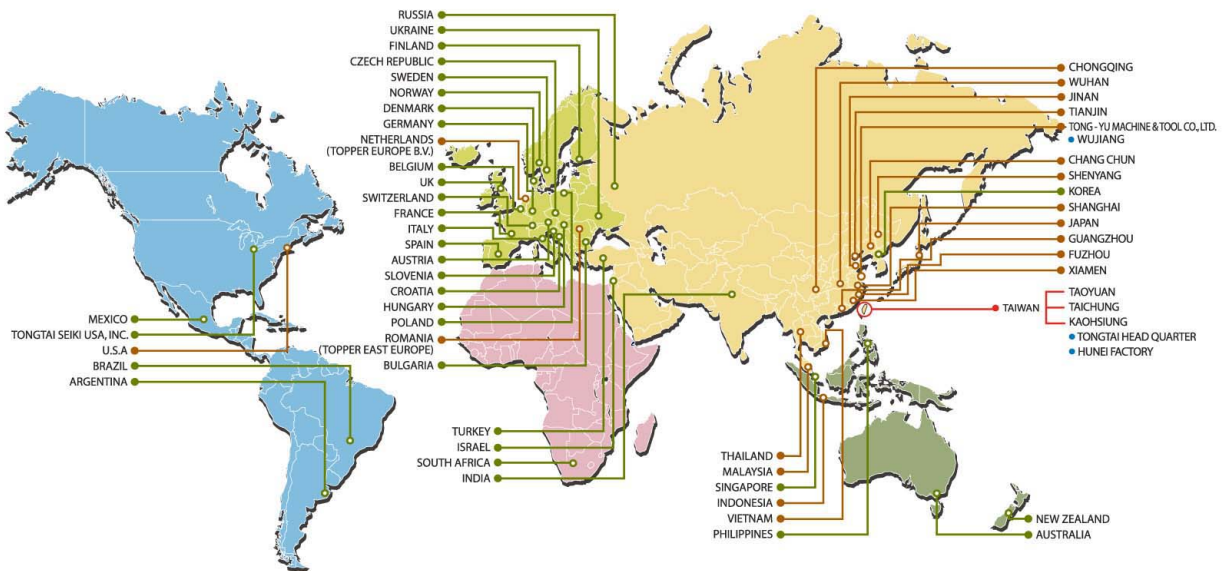

Tongtai Machine & Tool Co., Ltd.

- | | |
|--|--|
| <ul style="list-style-type: none"> • HEAD OFFICE
NO.3, LUKE 3rd. RD., LUZHU DISTRICT, KAOHSIUNG CITY, 82151, TAIWAN.
TEL : 886-7-9761588 FAX : 886-7-9761589/886-7-9761590
Website : http://www.tongtai.com.tw • TAOYUAN OFFICE TEL : 886-3-4551399 FAX : 886-3-4559730 • TAICHUNG OFFICE TEL : 886-4-23589313 FAX : 886-4-23588913 • TONGTAI SEIKI U.S.A INC. TEL : 1-845-2675500 FAX : 1-845-2675546 • Tongtai Machine & Tool Japan Co., Ltd TEL : 81-4-71438355 FAX : 81-4-71438360 • TONGTAI SEIKI VIETNAM LIMITED TEL : 84-435112529 • EUROPE OFFICE TEL : 31-161-454639 FAX : 31-161-454768 • THAILAND OFFICE TEL : 66-2-7443440 FAX : 66-2-3986518 • INDONESIA OFFICE TEL : 62-21-45850521 FAX : 62-21-45840522 • MALAYSIA OFFICE TEL : 60-3-78456815 FAX : 60-3-78456851 | <ul style="list-style-type: none"> • CHINA OFFICE
SHUZHOU TONG-YU MACHINE & TOOL CO., LTD.
TEL : 86-512-63430168 FAX : 86-512-63431622
E-mail : sales@tong-yu.com.cn • WUHAN OFFICE TEL : 86-27-59409109 FAX : 86-27-59409110 • SHANGHAI OFFICE TEL : 86-21-24208138 FAX : 86-21-34073262 • CHONGQING OFFICE TEL : 86-23-67865925 FAX : 86-23-67867717 • GUANGZHOU OFFICE TEL : 86-755-27222119 FAX : 86-755-27222115 • TIANJIN OFFICE TEL : 86-22-24417640 FAX : 86-22-24416738 |
|--|--|